

CRYSTAL SETS TO SIDEBAND

© Frank W. Harris 2006, REV 10

Chapter 14

VACUUM TUBE RECEIVERS AND TRANSMITTERS



My old-tech QRP project began the day I acquired an ancient type 216A vacuum tube. It's a wondrous Jules Verne-looking device with a round glass ball mounted on an elaborate nickel-plated brass base. It's the simplest three-element "triode" with all its guts in plain view. It has the filament in the center with a wire "grid" and a plate on each side of the filament. The base is imprinted with several patent numbers dating from 1907 to 1918. I decided I would use it to build a one-tube, crystal-controlled transmitter, just like the old days. As you'll see, there were problems with this dream.

The transmitter described in this chapter uses the most ancient vacuum tube technology I could, while still sounding pretty good on the air. Some of the parts I used were rare and unobtainable as new parts. However, if you can't find similar components at local swapfests, you can always buy them on-line. It's also possible to substitute more modern vacuum tubes that are still commercially available.

How old can you go?

I got a huge kick out of building the spark gap transmitter and crystal set receiver. My only regret was that I couldn't use them on the air. I wondered how old fashioned a rig can still be used today. About 1920 hams began to replace their spark gap transmitters with single tube LC tuned oscillators. In principle, these VFOs weren't that different than the VFOs described in

2. Chapter 14, Harris

chapter 10. Unfortunately the old VFOs were crude and drifted several kilohertz per minute. Obviously one of those state-of-the-art 1925 transmitters was not going to be acceptable today.

Spark gap transmitters were totally banned in 1927 because they splattered all over the band and wasted spectrum. After the international reorganization of the ham bands in 1929, the hams were confined to what were then considered “narrow” portions of the spectrum. Crystal control for hams was first introduced in QST magazine in 1927. The May 2001 QST had an article on ham transmitters used in the 1920s. The article warned that these early machines shouldn’t be used on the air. That’s no fun! In my local ham newsletter Yardley Beers, WØJF, described a transmitter he built in 1930 that sounded promising. It was a 10-watt, one tube oscillator with a type 210 triode. I figured that a triode oscillator with crystal control would be about as old-tech as I can go.

Why bother with tubes?

A homebuilder who has never built with vacuum tubes has missed an adventure. I told my electrical engineer nephew that I was building a vacuum tube transmitter. There was silence on the phone. “Why?!” he finally blurted. I was startled. To us geezers, “why” is obvious.

Let’s use trains as an analogy: I once had the privilege of riding on the French TGV (Le Tran Gran Vitesse) that translates to something like, “The Really Fast Train.” At 240 kilometers per hour the TGV is indeed speedy. When it passes another train on the adjacent track, the whoshing roar lasts less than two seconds. When TGV crosses a trestle, the ground drops away under you so quickly you feel as though you were taking off in a rocket. Modern ham equipment is like the TGV. Its attractions are sophistication and high performance.

Every summer narrow gauge steam trains puff and chug up and down Colorado canyons. These old-time anachronisms are packed with tourists. Steam trains aren’t popular for their performance, but rather for their sound and appearance. Vacuum tube transmitters, especially ones from the 1930s or 40s, don’t have impressive performance, but their visuals are great! Transmitters back then had great big coils, “bread slicer” variable capacitors, and wondrous glass vacuum tubes. Their plate current and grid drive meters look as though they belong in a power plant.

Vacuum tubes have the same function as transistors. They are constructed like filament light bulbs. Inside an evacuated chamber, usually glass, they have glowing filaments and intricate metal screens and plates. The lightbulb-like filament is heated to incandescence to drive electrons off its surface. The metal mesh, called the control grid, regulates the relatively large current passing through the vacuum between the filament (the cathode) and the metal plate. The grid is analogous to the base of a bipolar transistor or the gate of a field effect transistor.

Vacuum tubes were the first practical small-signal amplifying device. They dominated electronics for over 50 years. Most sophisticated analog circuits and even computer circuits were first implemented with tubes. When transistors became available, it was relatively easy for vacuum tube engineers to redesign the old circuits using transistors.



If tubes are so easy, why did my first two transmitters fail?

I've always been curious why my first two home-built transmitters did not succeed 49 years ago. My first transmitter was a 7 watt 80 & 40 meter rig built with plans in the 1957 ARRL handbook. It worked well around town, but hardly anyone heard me outside of town. Now that I've built modern QRPs and receivers, I realize that the average ham receiver back then was so poor that hardly anyone could hear a QRP. My second homebuilt transmitter was supposed to put out 30 watts but never worked properly. I lacked the test equipment and knowledge to find out why. Eventually I bought a commercial transmitter kit, just like the kits all the other novices were using.

In the transmitter described below, the power supply turned out to be my biggest obstacle. I'm convinced that was also my biggest problem back in 1957. Yes, my power supply was able to supply the required power, but now as then, my power supply was too weak or "soft" to supply the needed power without a significant voltage drop. Whenever the transmitter drew current from the supply, the voltage crashed causing the transmitter to run in bursts called "motor-boating." Since I didn't have a high frequency oscilloscope back then, I couldn't see what was happening.

The power supply

Vacuum tubes work by conducting electrons across a vacuum. Personally, I'm amazed that's even possible. But once you get past that, it shouldn't be a surprise that a vacuum tube has a relatively high resistance. So if you want to pass big currents, you need big voltages to push the current across the void.

$$\text{Power} = \text{Voltage} \times \text{Current}$$

To get big power you need either big voltage or big current, or both. The transmitter

4. Chapter 14, Harris

described here needs at least 250 volts to deliver 5 watts output. And because of its low energy conversion inefficiency, plan on supplying 15 watts DC power instead of just 5 watts. For example,

$$15 \text{ watts} = 250 \text{ volts} \times 60 \text{ milliamperes}$$

High voltage power supply safety

The chief disadvantage of high voltage is the danger of burns and shock. Vacuum tubes almost always operate at high voltages, typically over 100 volts. For high power ham band amplifiers the plate voltage can be 1000 volts or even 3000 volts DC. The bad news is that this can cause a severe jolt and burn when your finger touches the **DIRECT CURRENT** supply. The good news is that, although high DC voltage may knock you across the room, badly burn you, and scare the heck out of you, high DC voltage rarely kills anyone. It can kill, but usually doesn't.

Shock

Technically, the word *shock* means electrocution, so DC voltage usually doesn't "shock" hams. On the other hand, a 1000 volt DC power supply has 1000 volts of **ALTERNATING CURRENT** on its rectifier. If you get your hands across that, death is quite possible, even likely. Any power supply that plugs into the AC mains will have at least 120 volts AC on it and that's plenty to kill you. All power supplies are potential killers if you touch high AC voltage. In contrast, when 60 Hz AC voltage is below about 20 volts, it approaches being "safe." However, if you wet both hands, grip the two leads firmly so that 10 milliamperes of AC current passes through your chest, even 12 volts AC can kill you. In summary, it pays to be extremely cautious with AC voltage. Whenever possible, unplug the power supply before you work on your line powered equipment.

RF burns

Another safety issue is RF burns. High frequency, high voltage, radio frequency AC voltage doesn't shock you because your nerves and muscles can't respond fast enough to be polarized by the changing voltage. However, RF voltage can burn large holes in your hand. If you touch the plate circuit of your vacuum tube transmitter, you can expect at least a small hole in your skin. And, the higher the RF power you are running, the bigger the hole it will make. In summary, any voltage, AC, DC or RF, higher than roughly 50 volts deserves great respect. Your first lesson on working with vacuum tubes should be *don't touch anything until the power is turned off*. And, after the power is turned off, *be wary of large capacitors that may be charged to a high DC voltage*.

The Vacuum Tube QRP Transmitter

Once I began planning my tube QRP, reality began to sink in.

* First, I only have one antique 1918 tube. I'd hate to break it.

* Second, this tube has no cathode. It just has a simple filament. This means that the electrons come directly off the filament. A simple tungsten or carbon filament gives off electrons reluctantly, so these early tubes had low operating currents. That meant that my QRP transmitter

5. Chapter 14, Harris

would be extremely weak, perhaps a few milliwatts. There was a good reason that many hams used spark-gap transmitters until 1927. Power tubes weren't available until the 'twenties. It was hard to generate any significant power output until tubes were developed that could handle hundreds of milliamperes of current, instead of just a few milliamperes. Also, I'll bet power tubes back then cost a fortune.

* According to my 1979 ARRL handbook, "it is almost impossible to build a one tube CW transmitter that doesn't chirp to some degree." I guess chirp was normal in the old days. But today your signal will be roundly criticized if you dare to chirp at the modern hams who rule the airwaves today. So much for a one-tube transmitter.

* A related problem is that, the better a keyed oscillator sounds, the less output power you will get from it. In other words, a keyed oscillator that sounds good puts out little or no useful RF power. I began to understand that my 100 milliwatt transmitter might easily end up as a 20 milliwatt transmitter.

In my opinion, 1930s technology is about as early as you can go and not embarrass yourself today. I eventually built my transmitter using tubes that I had salvaged from old radios built during the 1930s. I like tubes from that era because they are big and spectacular. More modern tubes from the 40s and 50s are only large if they handle high power. Moreover, their glowing filaments are largely hidden by their cathode sleeves.

In the design described below I used a simple triode as a final amplifier. I believe the filament has been treated with thorium so that it emits electrons readily. Triodes have relatively low gain and were not very linear in their amplification characteristics. The tubes I used were type 68 and type 71. If you can't scrape up some old tubes, the more modern 6L6 is still available commercially. To eliminate the chirp, I used two more tubes to drive the final. So my single tube QRP ended up a 3-tube transmitter. And all I get out of it is 5 watts! The oscillator runs at very low power and can be keyed with little chirp. The oscillator is followed by a "buffer" amplifier, which amplifies the tiny oscillator signal up to the level where it can drive the final. My oscillator and buffer are type 41 tubes, which are small power pentodes. They look ancient, but were made in the 1930s and are equivalent to the more modern and still available 6V6 or 6K6 tubes. 6V6 and 6K6 were manufactured during the 1940s and 1950s and can still be bought from RF Parts Company and other companies.

Vacuum tube amplifiers

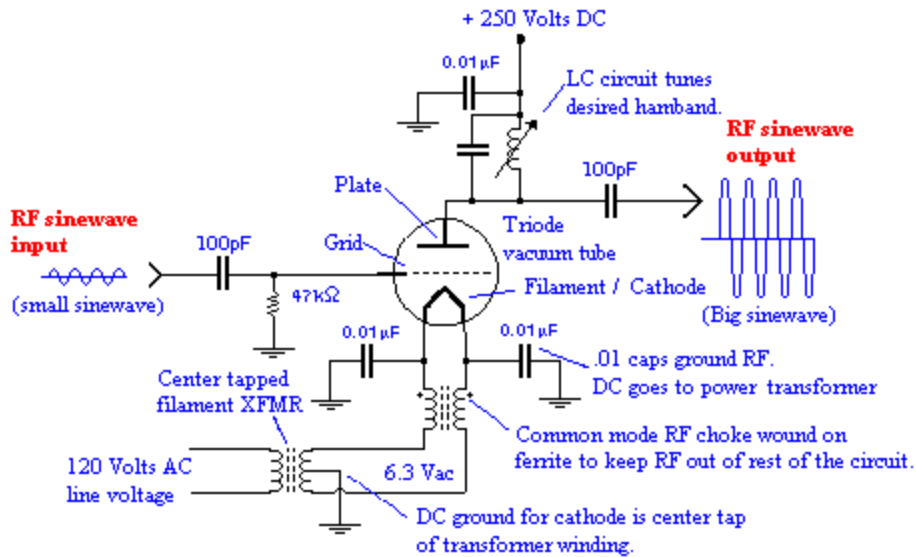

A vacuum tube RF amplifier

The simplest tube is a three-element device. The *control grid* is analogous to the gate or base of a transistor. The *plate* is analogous to the drain or collector and the glowing filament, which acts as the *cathode*, is comparable to the source or emitter. Tubes are principally voltage-controlled devices, although there is a small current that flows into the control grid. The control grid modulates the much larger current that flows from the filament to the plate. So as you would expect, the input signal is placed on the grid and the output signal is the current passing through a load resistor or load inductor, as shown above.

A filament - three circuits in one

Referring to the diagram above, what is all that stuff wired to the filament? This is the kind of complexity that drives beginners in electronics into other lines of work. Actually, once you unravel the parts, it isn't so bad. The difficulty with using an ancient filament tube is that the filament has three jobs to do simultaneously.

Signal cathode function First, the filament serves as a *cathode* to launch our radio frequency current from the chassis ground toward the plate. That is, it serves the same role as an emitter in a bipolar transistor or a source in an FET. RF conducts easily through 0.01 microfarad capacitors, so they conduct RF up from ground into the filament. The common mode RF choke keeps the RF out of the filament transformer. (These chokes were described in chapter 12.)

Heater function Second, the filament must be heated in order to boil the electrons off the filament and into the vacuum. The filament heat function is provided by a 6.3 volt, high current AC signal. So it's necessary to pass a big, low voltage AC current through the filament to warm it up, just like a toaster element. On the other hand, we don't want 60 Hz AC impressed on the signal we are trying to amplify. If we didn't take special steps to prevent it, the guys we are talking to would hear a big 60 Hz hum on our signal.

To keep the AC out of the radio frequency signal, the single loop of filament is powered by AC voltage that is referenced to ground in the center of the filament winding. That is, one

7. Chapter 14, Harris

side of the filament is connected to 3.15 volts AC, while the other half of the filament is connected to 3.15 volts AC with the opposite polarity. In the center of the filament, the voltage gradient passes through zero volts. The 60 Hz AC filament current biases the current flowing across the vacuum. However, because of the grounded tap on the transformer winding, half of the filament is shedding extra electrons, while the other half is shedding fewer electrons. As a result, the 60 Hz signal is cancelled and the RF signal the amplifier produces is not modulated with 60 Hz. Whew!

All this filament complexity is a nuisance, so newer tubes like the 6V6 and 6L6 have a metal tube surrounding the filament that is heated by the filament. When hot, it is the cathode that gives off the electrons. In that way, the heater function is electrically separated from the signals on the cathode.

DC bias function Third, every tube or transistor circuit has an optimum direct current operating point for the kind of amplifier you are trying to build. For example, if you want a high fidelity audio signal amplified with as little distortion as possible, the bias of a tube is turned half way *ON* at rest. That is, it is biased to operate class A. In class A, as the audio signal goes positive and negative from the resting point, the amplification will be equal for rising and falling voltage levels. If the operating point were wrong, the upper or lower half of the signal might be amplified more than the other, or perhaps cut off all together. Any distortion would ruin the sound of the music. Unlike bipolar transistors, the tube is already half-turned-on with no forward bias resistor going to the grid from the plate voltage.

In the case of a CW transmitter RF amplifier, the bias for a tube is simple: We just ground the DC on the cathode to provide the correct bias. In the case of a vacuum tube CW transmitter, we use this ground connection to turn the amplifier on and off. To send Morse code the telegraph key is used as a switch between ground and the center tap of the filament winding on the transformer.

The RF sinewave oscillator

Modern radio began with the vacuum tube sinewave oscillator. An RF oscillator consists of an RF amplifier that amplifies its own output. That is, a bit of feedback from the output is returned to the input causing the tube to produce a large sinewave output signal. Tube RF oscillators operate on the same principles as the transistor RF oscillators discussed in chapter 6 and chapter 10. If building an adequate transistorized VFO is difficult, you really don't want to use a tube VFO on the air today. I tried it and the criticism wasn't pleasant. Consequently, my old tech QRP uses crystal control.

Quartz crystals

While building my transmitter, I discovered that the old crystals in my junk box no longer oscillated. When new, crystals are so reliable that it never occurred to me that old crystals might not work. My crystals ranged in age from 20 to 50 years and hadn't been used in decades. The ones that still oscillated did so only under extreme stimulation. Fortunately for me, they were large, old-style FT-243 crystal holders that can be unscrewed and disassembled. I took them apart and cleaned the parts with alcohol. Two of them began to oscillate again, but the others remained inert. I suspect the rubber gasket gives off a vapor that condenses on the crystal and literally gums up the vibrations. In summary, if you try to use old crystals and the oscillator

doesn't work, or if it only delivers a tiny signal, you need to clean the crystal or buy a new one.

Triode and pentode oscillators

To be "old-tech," I started with triodes without cathodes. The oldest power tubes I had in that category were the type 68 and 71 tubes. I quickly re-learned that the output signal from a triode varies with the power supply voltage. Those other grids in tetrode and pentode tubes make the amplified signal relatively independent of the power supply voltage. To say it another way, a pentode tube has V/I characteristics that resemble NPN or N-channel transistors. This was particularly important for the crystal oscillator. The supply voltage sags slightly when the key is depressed and causes chirp. When using a triode, I could never quite eliminate the chirp, so I ended up using a type 41 pentode. Pentodes work fine.

Old tech circuit boards

I used a genuine old-tech circuit board made from a pine tree. A wooden board lets me move parts around inside the metal chassis and swap parts with little effort.



Since 6-pin and short 4-pin tube sockets aren't available anymore, I had to make my own tube sockets by drilling holes into a fiberglass perf-board. To grip the tube pins, I wrapped solid copper wire around them. This worked much better than I expected. I can even unplug and replace tubes.

The best oscillator circuit

There are several different vacuum tube oscillator circuits. The one below is the easiest to understand and produces the biggest output signal. The crystal, which is usually wired in series with a capacitor, is connected between the plate (the output) and the grid input. This puts big voltage on the crystal and produces an extremely strong oscillation. I was able to get 10 watts out of this oscillator with a 300 volt supply. That would be great, but this oscillator is difficult to key on and off for Morse code. Mine started up so slowly it was only able to generate dashes. The oscillator simply would not start in time to send "dots." It sounded more like a sick bird than Morse code. Its chirp was beyond "bad."

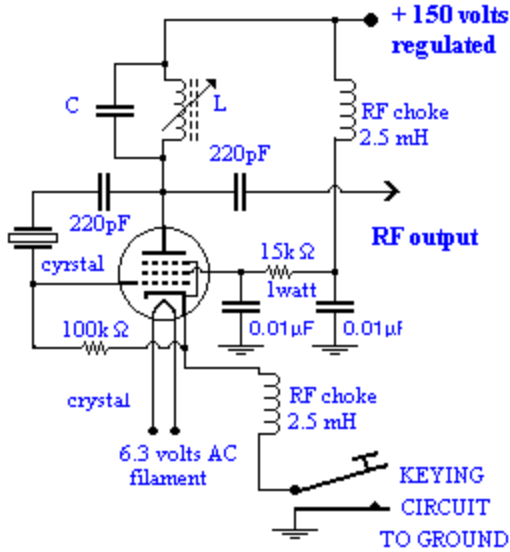

A powerful but unstable tube oscillator
A better tube oscillator for CW

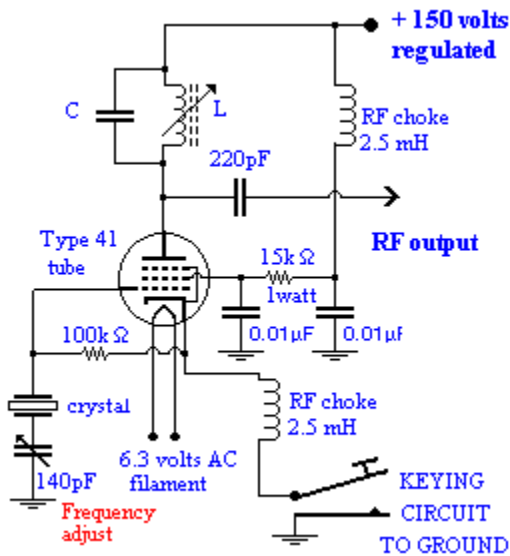

The circuit on the left is the oscillator used most often in old vacuum tube transmitters. The first question you probably have is, “Where’s the feedback?” There is no visible connection between the input grid and the output plate. However, there is feedback between the cathode and the grid by means of the 100K resistor. There is also feedback by stray (accidental) capacitance between the grid and plate. Remember that a vacuum tube is already turned halfway “on,” even when the grid voltage is zero. If there is any random change in the plate voltage (and/or cathode voltage), a tiny voltage will be coupled to

the grid. When this change in voltage appears across the crystal, the crystal will respond, thereby reinforcing an oscillation at the crystal resonant frequency. The advantage of this oscillator is that it keys well and makes good Morse code. The bad news is that the output signal is small. Mine only put out 6 volt peak sine waves. This compared with 30 volt sinewaves when I used plate-to-grid feedback. As seen in the diagram, I eventually settled on using regulated 150 volts plate voltage.

Notice that there is a 1-watt power rating for the 15K Ω resistor. Because of the high voltages, resistors in tube circuits often dissipate at least ½ watt. Wherever the power rating isn't mentioned, assume it is ½ watt. In ham transistor circuits it is rare that a resistor needs to be

more than $\frac{1}{4}$ watt and it's easy to forget that power dissipation is even a consideration.

Old time voltage regulation

My tube oscillator was powered by a simple, line-powered transformer high voltage supply. When the oscillator was in “standby,” the plate voltage on the filter capacitor rose to a level proportional the height of the power line sinewaves. Then, when I pushed down on the telegraph key, the voltage crashed to a lower steady state. This caused a noticeable “chirp” in the tone.

To fix this I used a 150 volt regulator tube. These tubes are the old-time equivalent of a Zener diode. Regulator tubes are simply glass vials containing low pressure inert gas. They have two electrodes. A central wire “cold cathode” runs down the center and a cylindrical plate collects the electrons from the cathode. When voltage is applied across the two electrodes no conduction occurs until the voltage reaches a threshold voltage where the inert gas ionizes into a glowing plasma. As the current through the gas increases, more and more gas is ionized and the voltage across the tube remains approximately constant. By designing tubes of different dimensions and using different mixtures of gases, the tubes regulate at different voltages. To regulate my oscillator supply I used a 0D3 tube that regulates at 150 volts. This trims the ripple off my supply voltage and greatly improves the sound of the CW. The 0D3 regulator glows with a lovely violet color.

The travails of tubes

After building my own rig, I now suspect that “normal” signal quality was really poor back in the bad old days. Yes, I was able to build a one-tube, crystal-controlled oscillator that keyed well and wouldn't be criticized for key clicks, chirps, drift, sag, or any of the other vacuum tube diseases. Unfortunately, it only put out 300 milliwatts. As the ARRL handbook said, it's almost impossible to build a one-tube transmitter than doesn't chirp. I think they're right. I needed at least a two-stage transmitter.

The final amplifier

I still wanted to use the type 68 triode as my final. 68s have a simple, rounds shape like tubes from the 1920s and they have a big, open filament that looks like an orange, glowing, bread toaster element. You can almost imagine dropping little Pop Tarts down in there for breakfast. The type 71 worked as well as a 68, but the glass has the newer, double-curved shape. Unlike more modern tubes, all three elements of these triodes are plainly visible. In order to operate a triode filament as a “cathode,” the filament transformer winding must be insulated from ground and the DC taken off through a centertap. Since both sides of the filament are DC inputs for the cathode function, the cathode choke should be a common mode design.

I made the common mode choke from an FT50-61 modern ferrite toroid core. Oh, well, close enough. They had pretty good powdered iron cores back then. I wound two 12 turn windings around the core as if I were making a bifilar transformer as described in chapter 6. Instead of connecting the windings together as described earlier, this time I kept them electrically separate and wired them as shown below. The windings at one end of the pair were wired to the filament, the windings at the other end were connected to the filament transformer as shown below. The dots on the transformer mean that if positive voltage appears at the end of the winding with a dot, then positive polarity will appear on other winding at the location of the

second dot.

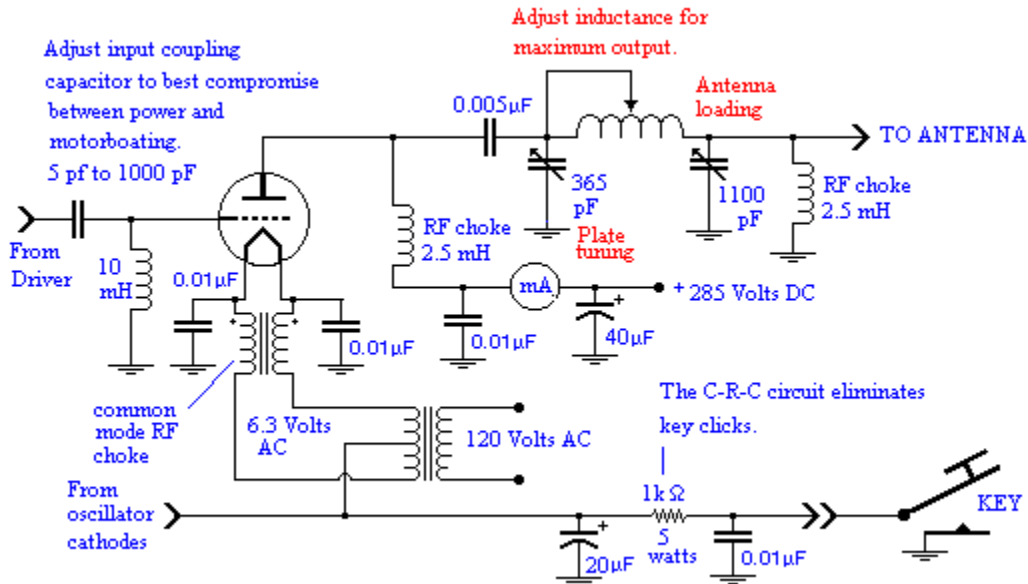

My triode final is shown above. Rather than amplify the input signal, the triode preferred to oscillate all by itself. When it wasn't self-oscillating, the drive from the puny oscillator was insignificant to get any useful power out. I wondered how typical novice transmitter kits 40 years ago managed with only two tubes. I decided, "It must be those high gain pentode finals!" I threw together a 6L6 final and tried it out. No change. The 6L6 had the same gain as my ancient triodes. If this was going to work, I needed more grid drive. I finally concluded that those old Heathkits, Knight kits, and Viking Rangers were just darn well engineered. They achieved terrific performance with few parts.

Key clicks

Notice the C-R-C filter in the keying circuit. That's what I had to do get rid of the key clicks. Key clicks are sharp, unpleasant clicking sounds on the Morse code caused by the dots and dashes turning on and off too rapidly. Although my transistorized CW transmitters seem to have rise and fall times just as abrupt, my transistorized rigs have had practically no problem with clicks. I don't understand this, but the C-R-C filter in front of the key causes the tubes to key on and off gently and the tube transmitter no longer clicks.

Buffer amplifiers

After struggling for a few hours, I eventually added a "buffer amplifier" made from another type 41 pentode between the oscillator and the final. Now I had enough drive for the triode final.

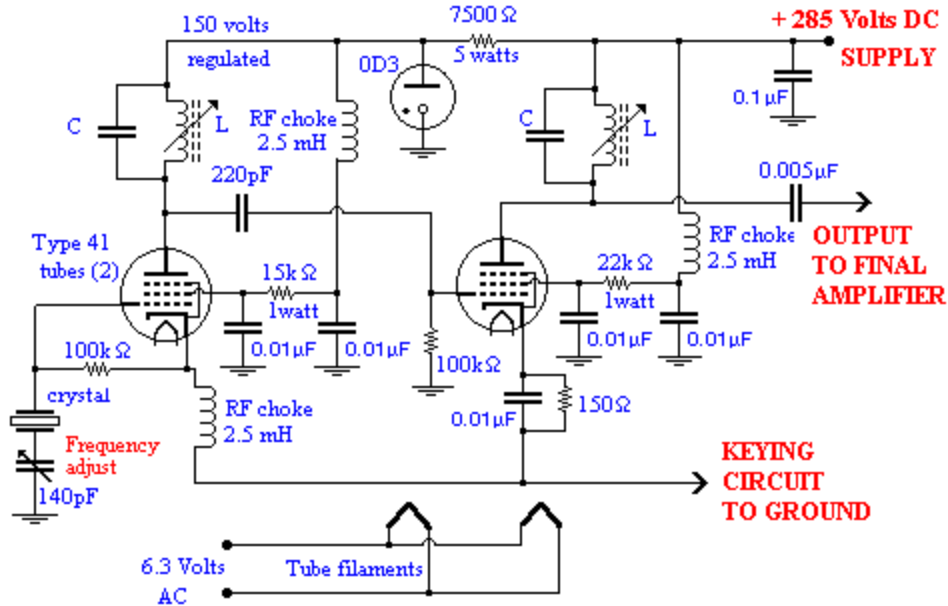

Oscillator and buffer stages

The oscillator tube drives a buffer amplifier to increase the drive to the final. Notice the OD3 regulator tube for the oscillator plate supply. A 7500 ohm resistor drops the 285 volt supply down to 150 volts while the regulator tube holds it at that level.

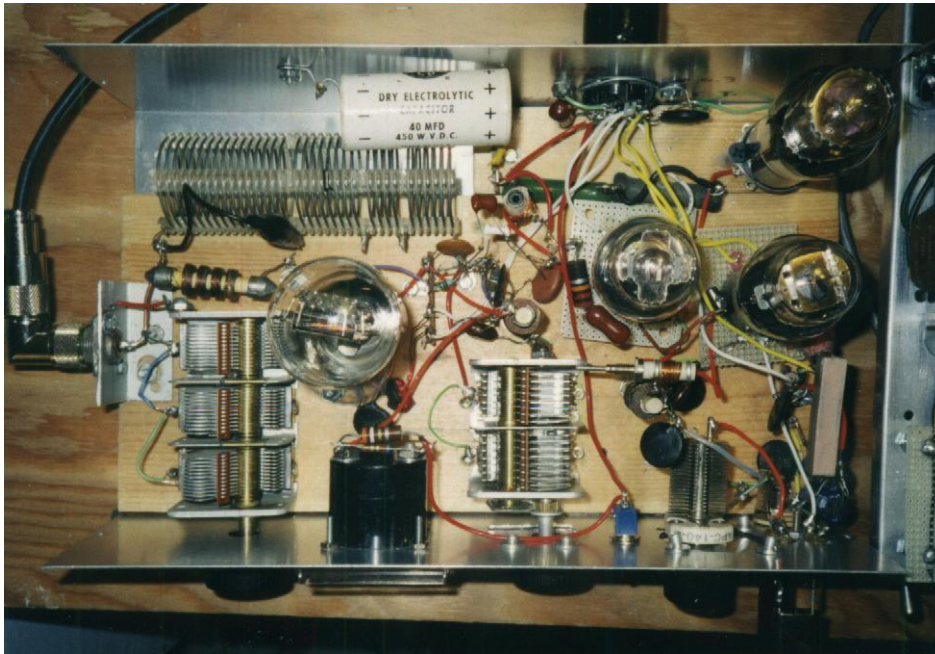

The completed 40 meter transmitter

The final amplifier is on the left. The oscillator, buffer, and regulator tube are at the right rear. The plate coil is the long, tapped coil at the rear. In theory it was supposed to work on several bands, which is why the coil has the multiple sections. However, so far I have only gotten it to work on 40 meters. The plate coils for the oscillator and buffer were wound on slug-

tuned coils, which were the popular way to do it back in the vacuum tube days.

Triodes chirp

While up to my ears in vacuum tubes, it dawned on me that those homebrew “kilowatt linear amplifiers” in the old ARRL handbooks made from triodes can not really be linear. The output voltage of a triode varies with the supply voltage, not just the grid voltage. Well, they could be linear, but the operating range along the load line would have to be really narrow and the supply would have to be perfectly regulated. I doubt those designs meet either of those criteria.

THE POWER SUPPLY

An inadequate power supply made from old-fashioned parts

Before I could try out my QRP transmitter, I needed a power supply. I first tried to use a power supply salvaged from a junked 1935 radio. Unfortunately this power supply didn't deliver enough power for a QRP transmitter but, as always, it was educational.

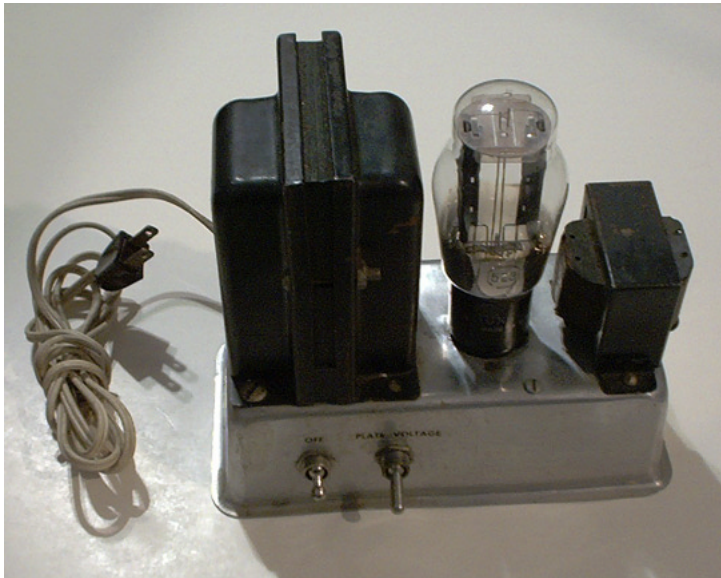

A power supply made from parts salvaged from an ancient radio.

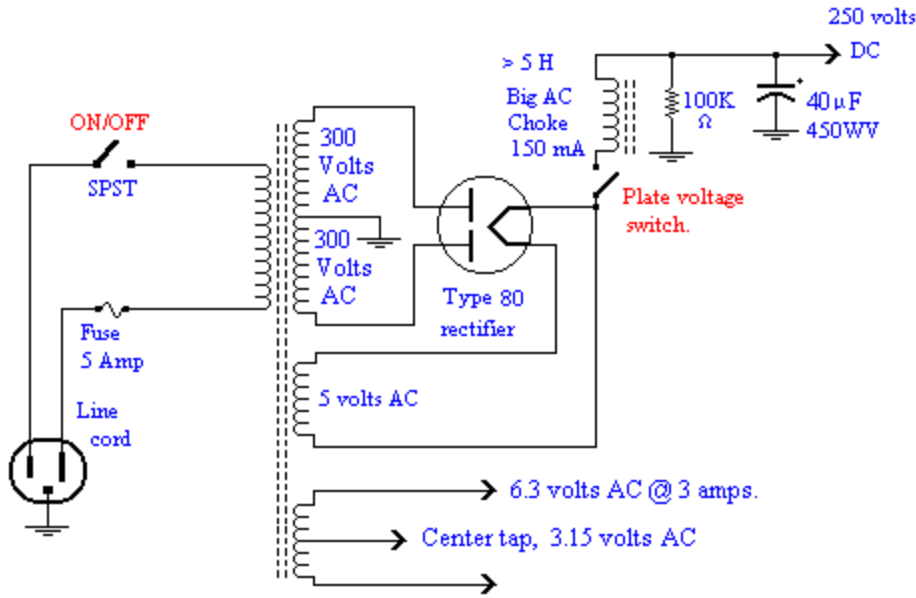

Schematic of the 1935 power supply

The AC power from the wall comes into the supply and first encounters a 5 ampere fuse. In case the supply is shorted, the fuse can blow and prevent further damage. Five amperes is a larger fuse than needed, but it's within electrical standards for small appliances. A switch connects the power transformer primary winding with the AC line.

The transformer is equipped with three secondary windings. A high voltage winding puts out about 300 volts at 30 milliamperes. Actually, it has two 300 volt windings that allow us to achieve full wave rectification with just two diodes. The type 80 tube contains two anodes that share a common cathode/filament. A filament winding delivers 5 volts at about 2 amperes. This winding is used exclusively to heat the rectifier filament. The winding also has the 300 volts DC on it, so it must remain separate from other circuits. An independent filament winding puts out 6.3 volts at about 3 amperes.

The 6.3 volt winding is center-tapped. In other words, it is a 3.15 volt winding in series with a second 3.15 volt winding. The center tap is essential if you wish to use an ancient tube that has no separate cathode and must use the filament as a cathode. The center tap offers balanced access to the filament circuit to complete the main circuit between the plate and filament. Without a centertap, 60 Hertz power line noise will be impressed on the current and will appear in the transmitted signal.

Tube rectifiers

Before the high voltage can be used, it must be rectified and converted to DC. Vacuum tube rectifiers are a kind of diode and only conduct electricity in one direction. Specifically, they conduct electrons from the filament (or heated cathode) to the plate. The round circle symbol with the single filament and two plates is a dual, "full wave" rectifier. It converts both halves of the AC signal into a single DC signal in which both rectified halves of the sinewave have positive polarity. Both sides of the high voltage winding are connected to the two plates so that, at any moment, one side is always conducting while the other is not. The two positive voltages

are added together at the common filament for a single, continuous, positive output.

Ripple filtering

In order for Morse code to sound clear and pure, the voltage driving the transmitter must have no ripple left over from the sinewave. This is done with an “L” filter. An inductor and a capacitor make the two arms of the “L.” The choke, being a large 5 Henry inductor, doesn’t allow the current flowing through it to change rapidly. This prolongs the charging period of the capacitor and helps smooth out the ripple. Many designs add a second big filter capacitor on the input side of the choke. This practice causes big surge currents to flow into the first capacitor and may saturate the transformer. The saturation in turn causes the transformer to heat and probably isn’t as effective as putting both capacitors on the downstream side of the choke.

So much for theory. In practice, a receiver needs far less DC current than even a small transmitter. One difficulty was that the old-fashioned type 80 tube rectifier cost me 50 volts drop all by itself. Another problem was that the L and C filter were insufficient to prevent the ripple from making the Morse code sound rough and harsh.

But worst of all, the transmitter drew so much current that the voltage dropped precipitously and it tended to run in “bursts” called *motorboating*. One cure is to use the smallest input coupling capacitance to the grid of the final amplifier. With luck, this can stop the motorboating and still give good output. With a soft (sagging) power supply the coupling cap may need to be as low as 5 pF on 40 meters.

I also tried to use an ancient type 83 mercury vapor rectifier tube. This is a vacuum tube rectifier that contains a touch of mercury vapor gas inside. This lowers the resistance of the tube and raises the current capacity of the power supply. The type 83 was a big improvement, but still not adequate for on-the-air use. I’ve had quite enough bad signal reports, thank you.

Checking out an old transformer

Big power transformers have always been costly. That’s why my 1957 novice transmitter power supply was so wimpy - I thought I couldn’t afford a bigger one. The old ham radio handbooks suggested using power transformers from vacuum tube TV sets. However, junk vacuum tube TVs are rare today. If you have such an old TV, remove the transformer from the chassis carefully being sure to label which pair of wires (usually black) go to the AC line.

Suppose some friend from your ham club gives you a power transformer and assures you it is “perfect” for building a transmitter. He hands you a 5 pound lump of iron with a nest of unmarked black wires protruding from the bottom of the transformer. You think to yourself, “Now what?”

The first step in checking out an old transformer is to strip the ends of the wires so you can measure the resistance of each winding. If you’re lucky, you will find that, once you clean off the dirt and tar, the wires are color-coded. The most common color codes are as follows:

two black wires - the 120 volt primary winding.

two red wires - the high voltage secondary for the plate supply, typically 1000 volts centertap for a 50 watt transmitter.

one yellow and red stripped wire - the center tap of the high voltage winding. This wire will

be grounded in a full-wave rectifier circuit.

two yellow wires - a 5 volt filament winding is usually good for 1 or 2 amperes. This is used exclusively for the rectifier filament.

two green wires - a 6.3 volts filament winding. This supplies the filament current for the transmitter tubes.

one yellow and green stripped wire - This is the center tap for 6.3 volt winding. You'll need this if you use an old-time triode vacuum tube final amplifier. If you use a more modern tube with a separate cathode, then just tape off the end of the centertap wire and fold it up neatly. Don't cut it off. Someday you may want it.

Often there are no visual clues telling you which winding is which. Or sometimes the windings are just solder eyelets mounted on Bakelite strip at the edge of the transformer. Using your ohm-meter, measure the resistances of the windings picking them out one by one. Label them with tape and write down the resistances. The highest resistance winding will be the high voltage winding. For example, it might read, say 40 ohms. The high voltage center tap will have half as much resistance as the whole winding measured end to end. The 120 volt primary winding will have the next highest resistance. The lowest resistance windings will be the two filament windings. These will have an ohm or two at most.

Once you think you have the windings figured out, you need to test them before bolting and soldering the transformer into your transmitter. If this isn't going to work, you want to know as soon as possible. Now that you are considering plugging it in, you have a great opportunity to electrocute yourself, trip circuit breakers, and start fires. But if you're careful and proceed thoughtfully, testing a transformer can be done safely. The idea is to limit the current that flows into the transformer. That way nothing terrible will happen even if you screw up or if the transformer is internally shorted.

Testing a power transformer

To test the transformer you must connect the winding you believe to be the primary to a source of 60 Hz voltage. How safe you want to be is your decision. But AT VERY LEAST don't plug the test transformer into the power mains without soldering a 10K ohm (or higher) resistor in series with the primary winding. That way, even if the primary is a dead short, little current will flow and nothing bad will happen.

Measure the open circuit secondary voltages with your multimeter set to AC voltage. Then you measure the open circuit AC voltage across each pair of windings you isolated earlier. Connect your voltmeter to the transformer secondaries using test clips. Don't just try to press the wires against test probes. You might slip.

Go through the windings one by one and you should be able to confirm the guesses you made from the resistance measurements. Whatever you do, don't just connect it to a line cord and plug it into the wall. Ideally, you could build a special test fixture equipped with an ON/OFF switch, isolation transformer, fuse protection, insulated test leads, and a variable impedance between the AC source and the test winding you believe to be the primary.

An adequate tube QRP power supply made from modern parts

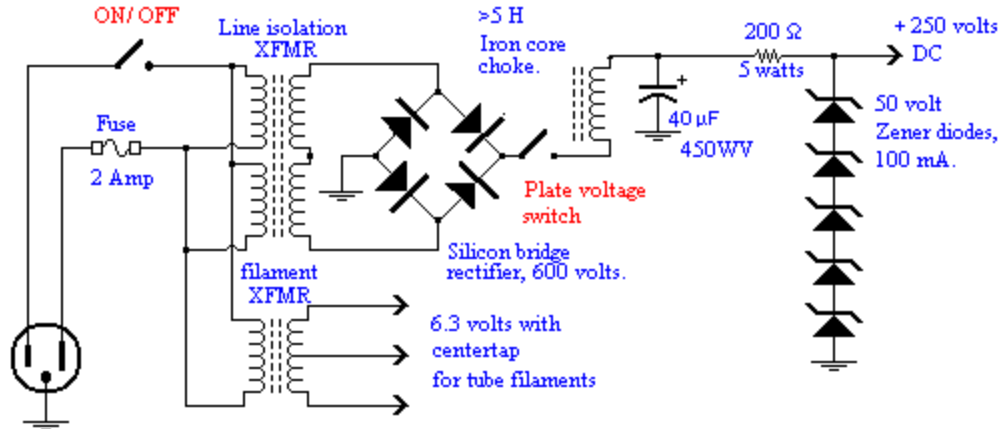

When my first supply worked poorly, I built another made from modern transformers and semiconductors. This supply was adequate to run the vacuum tube transmitter. Ideally it produces 250 volts at 200 milliamperes. This time there was no significant voltage drop across the modern bridge rectifier and the modern Zener diode string clipped off the ripple and gave me a pure CW tone.

I couldn't find an adequate, triple-winding transformer, but there are alternatives. Magnetek makes an isolation transformer that can isolate an appliance from ground for shock protection. (Magnetek / Triad part # VPS230-350 sells for about \$30.). It has four 120 volt windings. Each winding is rated at 350 milliamperes - plenty "stiff." That is, this supply behaves like a good voltage source over a wide range of current. These two pairs of windings may be connected in series or parallel. For this application you could put two windings in parallel for a 120 volt primary. The secondary windings can then be connected in series to give you a 240 volt secondary rated at 350 milliamperes. Notice the dot markings on the windings. These tell you the phase direction of the sinewave voltage. On the primary side, you must connect the leads so that the dots should be connected together. That way, the two windings will work together.

On the secondary side, the dotted end of one winding goes to the un-dotted end of the other winding. Notice that if you connect the secondary windings so that the two dotted ends or the two non-dotted ends are tied together, the voltages will cancel each other instead of add. Instead of 240 volts you would get zero volts.

The other power requirement for vacuum tubes is a 6.3 volt supply to light the filaments. Each tube filament needs about 0.5 to 1.2 amperes of current. Notice that roughly 5 watts is expended just to heat up each tube! Tube transmitters are inherently inefficient.

I used four modern silicon rectifier diodes that were rated for 600 volts peak inverse voltage and I arranged as a bridge rectifier. Since you aren't using a tube rectifier, you won't need a 5 volt filament winding like the one shown earlier in the 1935 power supply. You will need a separate 6.3 volt filament transformer for your transmitter tube filaments. To regulate the output voltage I used five 50 volt Zener diodes in series.

My supply made from modern parts can put out 42 watts and that's sufficiently "stiff" to deliver my measly 10 watts without sag. Using the modern silicon rectifiers I got 4 watts out of my transmitter.

A power supply for the tube transmitter constructed from old style parts

Although I now had the rig working, I still wanted to use old parts exclusively. Unfortunately, to use an old tube rectifier with full-wave rectification, I needed 480 volts centertap. So I added a second transformer. This worked, but the extra voltage drop across the type 83 tube rectifier cost me half my 4 watts! Finally I added yet another transformer and got the average, well-regulated DC voltage up to about 285 volts.

I tried using gigantic filter capacitors, but they weren't available in 1935 and they caused long-term sag. I was surprised to discover that a total of two 40 microfarad caps were plenty when used with voltage regulators. To regulate my 285 volts DC I used one 0A3 (75 volts) and two 0C3 (105 volts) gas tube voltage regulators in series. 0A3s glow with a spectacular orange color while 0C3s glow violet.

In order to regulate while the transmitter is keyed, the voltage regulator tubes should be at least slightly glowing at all times. For best regulation, you may have to reduce the 200 ohm current limiting resistor to 150, 100, or even zero ohms. You will probably find that the regulators only stay lit while the key is down when the transmitter is perfectly tuned to the antenna. When it is out of tune, the transmitter draws too much current and regulator tubes will be extinguished and essentially take themselves out of the circuit.

I have seen these old gas regulator tubes offered for sale at as much as \$30 each! Hopefully you can find some at a swap fest. Notice that I could have used six teeny 100 mA Zeners at less than \$2 each. Anyway, when all was said and done I had 5 watts of pretty good sounding CW. Behold! I have created the world's most inefficient transmitter!

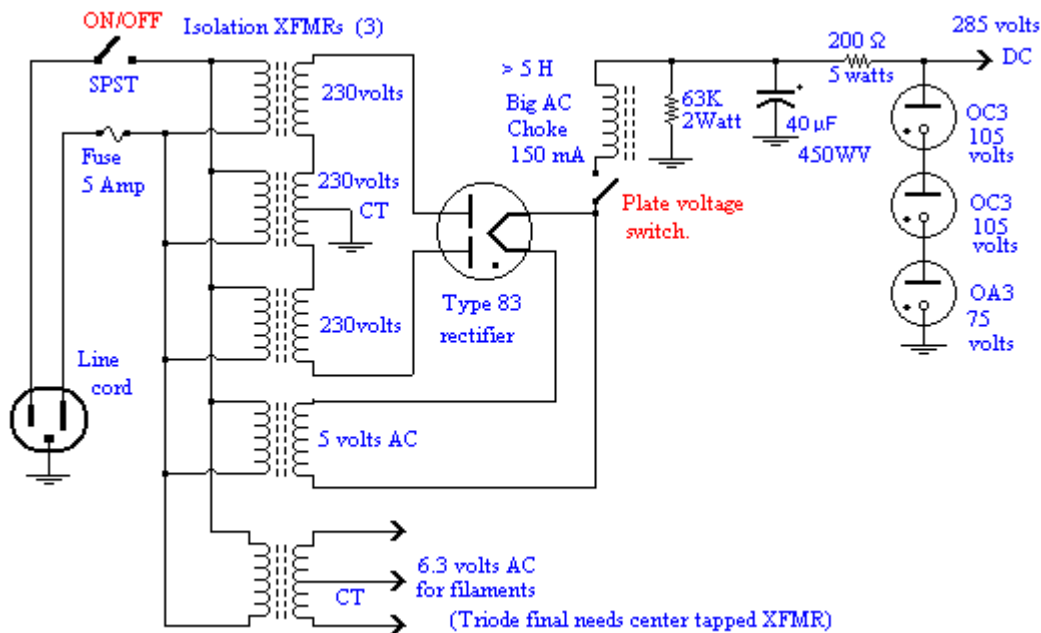

Schematic of the regulated QRP supply made with old-style parts

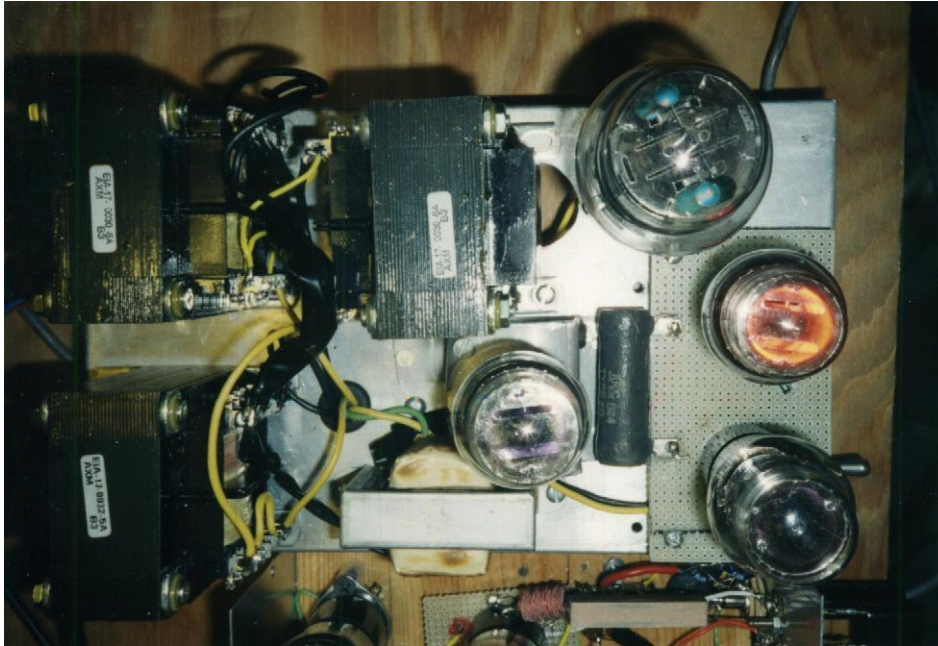

It isn't that you can't build modern high tech stuff with 1935 parts, it's just that the assembly becomes huge and expensive. Meeting modern specs with old parts reminds me of a scene in the movie Back to the Future III. In this time travel movie Doc Brown replaced a burned up integrated circuit from the future with a tube circuit the size of a laundry basket. It must have been a low scale integration chip!



Old-tech QRP

A happy ending

In conclusion, old parts aren't efficient in any way. On the other hand, you get to use a whole lot of them to accomplish very little and they look terrific. The voltage regulators glow orange and violet, but when you key the transmitter the glow flashes on and off inversely with the CW. When I first turn the mercury vapor rectifier on, mercury condenses on the glass in a silver-

white fog. Then as it heats, the mercury evaporates and the tube runs with a glorious blue glow with bright orange filaments. Great show biz! Oh, yeah. I forgot to mention the “mercury vapor rectifier hash” that you get to listen to on receive. Oh, and another thing - don’t place your transmitter supply transformers close to your receiver. The receiver may pick up a 60 Hz hum. You’ll probably have to turn off the transmitter high voltage supply during receive. There are lots of reasons these old parts are extinct.

Every year my local ham club has a "homebrew night." Hams who have built something during the previous year bring in their devices and give a brief show and tell. Over the years I have showed off most of the projects described in this book. They include all the most difficult projects, the SSB transmitter, the dual conversion receiver, etc. I think it's fascinating that the project my fellow hams remember best is the vacuum tube QRP. I demonstrated it with a Christmas tree light bulb for a dummy load and they all oohed and aaahed over the pretty glowing regulator tubes and lights. In the years since, they always act disappointed that I haven't brought in another vacuum tube light show. Food for thought!

So anyway, I can successfully work people with my old-tech QRP. QRP is quite popular. I call CQ, mention “/QRP” and I get lots of responses from other fanatics. Who else would answer an American “Ø area” RST 449 CQ? Usually we can barely hear each other, but we’re having fun. However, you never know! I got a 599 from Albuquerque. Maybe he was just kidding. Anyway, how old-tech can YOU go?

OLD-TECH SUPER-REGEN

How old fashioned a receiver can you use on the air today?

Once I had my old-tech, 1935-era CW transmitter working, I thought it would be fun to complete my ancient rig with an old-tech receiver. To be successful on the CW bands, I figured I needed a superhetrodyne with a crystal filter. In 1967 I built a pretty good vacuum tube CW receiver so I had little interest in doing the same project again. (There is a photo of this receiver in chapter 13.) The 1930 tubes would be much larger than 1960 tubes, but otherwise it would be the same project.

Yardley Beers, WØJF, told me about the regenerative receiver he built in 1930. I doubted it would work well enough for today’s bands because I had a previous experience with regenerative receivers. So Yardley didn’t inspire me to build another one. Then a few months later I worked Mike, NØMF. He was using a homebrew super-regenerative receiver made from modern FETs as described in QEX magazine. Obviously it was sensitive and selective enough to hear my QRP on 40 meters. Maybe a super-regenerative receiver wasn’t so silly.

Ancient tubes

I have never been able to bring myself to throw out vacuum tubes. I have boxes of them in my attic. I’ve always been especially fascinated by the earliest tubes. They have lightbulb-like glass envelopes, bayonet sockets and numbers like 201, 216, 224, 227, and 301A. This was my chance to build a really old-tech receiver.

I started by building an RF amplifier out of a type 201 tube. I had no specs for a 201, but

That is, the power supply is deliberately given a high source impedance with a series inductance (10 mH). This causes the tube to oscillate in short bursts. Normally, when RF circuits motorboat it's a darn nuisance and tough to get rid of. It's ironic that motorboating was my big problem with the transmitter and here it is vital to get the receiver sensitivity. The 10 mH choke can be seen in series with the plate of the tube on the right. The motorboating typically occurs at a rate of 1 KHz.

In a super-regen motorboating does three useful jobs: Maximum sensitivity and selectivity are obtained during the feedback near the peak of each burst. The sidetone caused by this oscillation makes an audio squeal that serves as a BFO. If you are listening to AM modulation, the regeneration control can be turned down until just below the point where the squeal begins.

Super-regeneration re-broadcasts what you're hearing

Unfortunately, if you wish to use a super-regenerative receiver today, it must be a two stage device. An RF amplifier (or other device) must isolate the oscillator from the antenna. Otherwise, you'll be rebroadcasting everything you're listening to on your receiving frequency. Even with an RF isolation amplifier, you'll be radiating a few milliwatts of RF signal. To demonstrate this, disconnect the antenna from your modern communications receiver so there are no signals audible on the band. Now tune the modern receiver to the same frequency as your super-regenerative receiver. Suddenly, coming out of the modern loudspeaker you'll hear exactly what you're hearing in the headphones of your super-regen. The super-regen really does rebroadcast the signals it picks up!

Super-regenerative design

When you think about it, a one-tube super-regenerative receiver is actually quite amazing. One tube is providing RF amplification, detection, audio amplification, and a BFO all in one tube. 80 years ago this economic efficiency made it possible for hams to afford to build receivers at a time when a single tube was a major investment.

Regeneration is accomplished by feeding back the output from the plate to the grid. In my circuit this is done with the 22 megohm resistor from plate to grid. The gain of the tube is adjusted by the pot that controls the voltage on the second grid. The 2nd grid is called the *screen grid*. The oscillation provides far more gain than a simple RF amplifier can achieve. It takes good sensitivity to hear hams on the HF bands. Moreover, the self-amplification greatly increases the circuit Q, making the amplifier much more selective than it would otherwise be.

For an audio output transformer I used an iron 12 volt filament transformer, i.e., 120 VAC to 12.6 VAC. It works fine and was easier than trying to find a real old time audio transformer. The secondary side goes to the low impedance headphones. The 120 volt primary side goes to the tube plate circuit.

The power supply

Bob, K6VGA, told me about the homebrew super-regen receiver he built back in 1935. He said its worse fault was AC hum. It was so bad, he replaced the AC power supply with batteries. After that story I figured I would have to filter the heck out of the power supply with a big choke, big capacitors, and a voltage regulator from the 1940 era. However, a voltage

regulator turned out to be overkill. Unlike my old-tech QRP transmitter, the power supply for the super-regen turned out to be remarkably easy. In other words, simple power supplies like the ones I tried to use for my transmitter worked fine for the receiver. Yes, the receiver hums slightly, but too little to bother me.

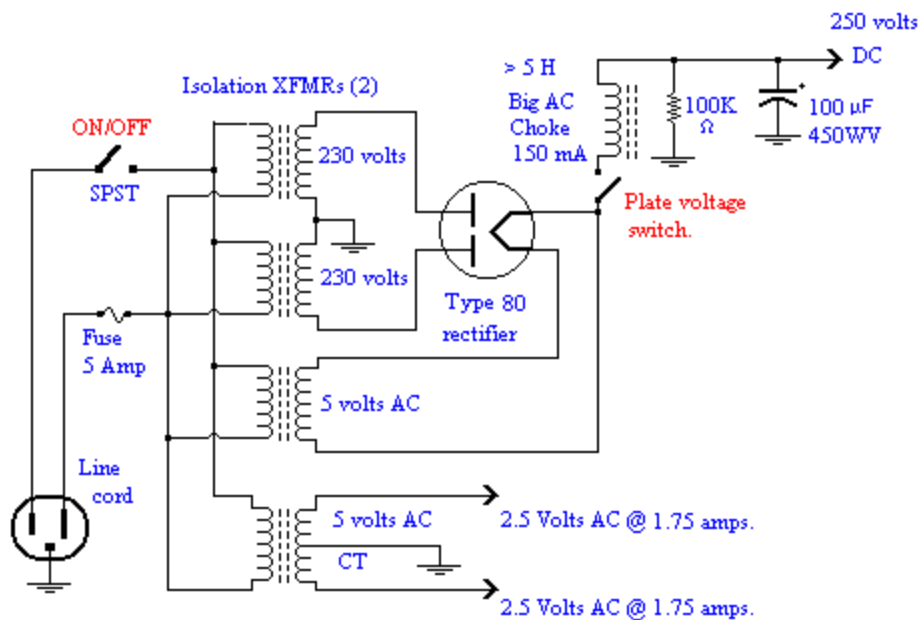

An old-tech power supply for the super-regen.

As explained earlier, you can't buy a new, old-time tube transformer with both high voltage and rectifier filament windings anymore. However, 5 volt filament transformers are still available as separate units. A center-tapped 5 volt, 2 ampere transformer is needed to provide the 2.5 volt filament voltage for the type 24 tubes. You could also use a 5 volt winding and wire the two tube filaments in series. The tube filament transformer must be separate from the transformer winding used for the rectifier. Otherwise all the filaments would have +250 volts DC on them.

In my receiver I used an old plate transformer I happened to have. However, you may use two of the same transformers I used for my old-tech QRP transmitter. For a choke I used the primary of yet another filament transformer. Because the current drain is so low, a voltage regulator tube isn't needed.

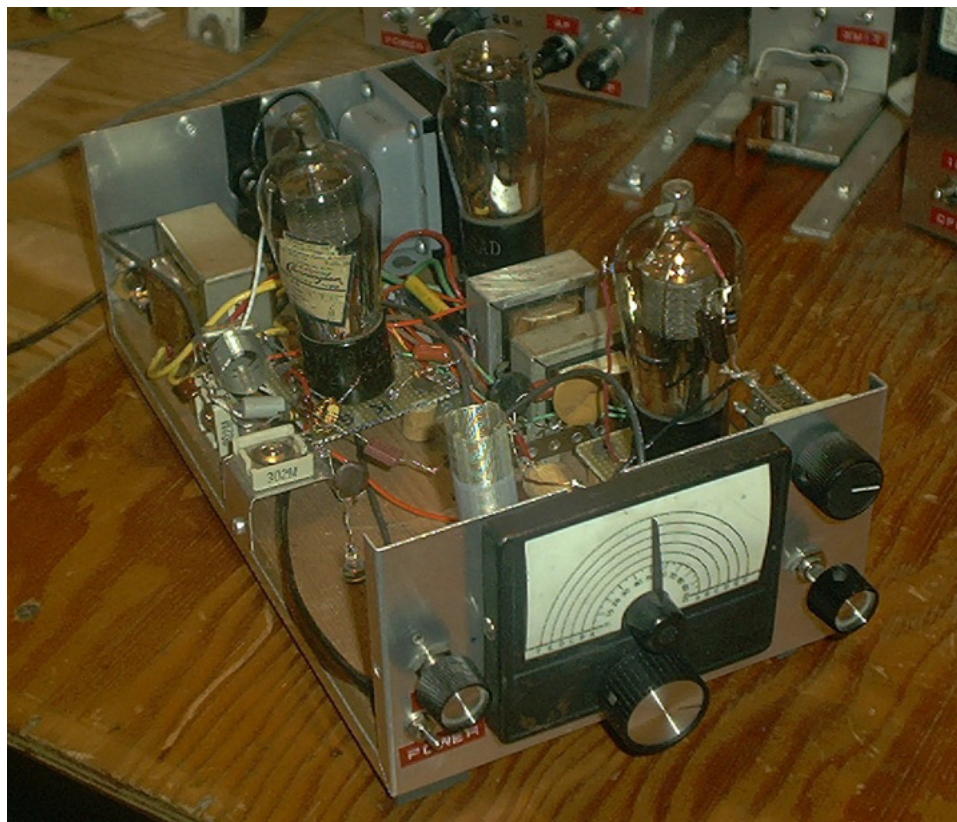

Super-regen on the modern hambands

In summary my super-regen worked quite well for listening to shortwave broadcast stations on the 31 meter band, around 10 MHz. These are extremely powerful stations like Die Deutsche Welle (Radio Germany) and various religious stations. To hear AM stations, the regenerative control is turned down just below where it begins to squeal.

To hear CW stations, the regeneration is turned up just above the squeal. The squeal modulates the Morse code and makes it audible. Unfortunately, as I feared, my super-regen isn't sensitive and selective enough to be used on the air today. Yes, I heard lots of ham CW stations on 40 meters, including guys I had worked before. The stability seemed OK once a signal was tuned in. But that's because I was hearing at least 20 KHz bandwidth at once. In other words, I was hearing half of the CW stations on 40 meters simultaneously. The worst problem is that the reception is "flaky." If I just touch a control, the pitch of the CW signal jumps to inaudible. Or it leaps from a nice tone to a harsh, static-like sound. When I try to tune it in better, the signal is likely to vanish altogether. Yes, I can work guys with this receiver, but it would be a stunt, rather than practical. How does it compare with the little direct conversion receiver described in chapter 7? There's no comparison. The transistorized direct conversion receiver is far better in every way.

In conclusion, the modern FET super-regenerative designs apparently achieve much higher Q and stability than I got using gigantic old-time parts with their stray capacitance and leakage inductance. But the project was fun and I learned a great deal. On the other hand, there's no reason I couldn't build a 1930 superhetrodyne using 6 or 7 ancient tubes and 1927 crystals. That would fill a huge chassis and require loads of work. Until I can muster the

25. Chapter 14, Harris

enthusiasm, I guess a practical old-tech receiver will remain one of those unfinished projects in my attic. But wait! I just got a QSL from Biz, WDØHCO. He claims that when he worked me he was using a super-regen made from two type-30 tubes. He found the design in a 1932 ARRL handbook. Hmm... Maybe I'm being too hasty.