

CRYSTAL SETS TO SIDEBAND

© Frank W. Harris 2006, REV 10

Chapter 8

POWER SUPPLIES

Once you progress past crystal sets, electronic projects almost always need a power supply. Low power projects, like a small receiver, can be powered with flashlight batteries or even a little 9 volt “transistor” battery. Other convenient sources of low power DC are *adapter plugs*. These are the black cubes a few inches square that plug into the wall and have a long, skinny cord that plugs into your recorder or small appliance. They deliver 6, 12, or other DC voltage at a few watts. Adapter plugs have the safety of a battery with the convenience of wall power.

Unfortunately, if you plan to power your QRP with household power, you’ll need more than a few watts. When you decide to plug a homebuilt circuit into the wall, you must confront some significant safety issues. Line-powered power supplies convert 120 volts AC into DC voltage at the required levels of voltage and current. Actually, a transmitter can also be thought of as an energy conversion device. It converts direct current into radio frequency current. In this chapter I’ll describe some power supplies you could use for your QRP transmitter. A 5-watt transmitter needs at least 10 watts of power with good voltage regulation.

Line-powered power supplies

The ideal power supply is called a *voltage source*. A voltage source is a power supply that can supply infinite amounts of current without the slightest waver in the voltage. For example: As every northern resident knows, starting a car can be difficult when it’s below zero. A cold battery does not supply as much current as a warm battery. So, when you turn the ignition key on a frigid morning, the battery voltage crashes.

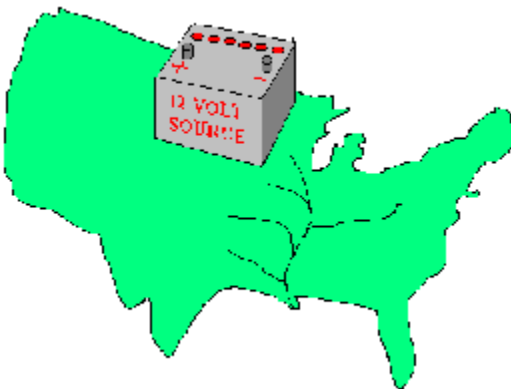

On the other hand, if you had a battery the size of North Dakota, the voltage would not drop a microvolt when you started the engine. Moreover, you could start all the other cars in Minnesota simultaneously without voltage drop. Of course, there are also other practical issues here. For example, your battery would need zero resistance battery cables, zero resistance connectors, etc. Well, you get the idea: The ideal voltage source should not lose any voltage, no

matter how much power it supplies. Using ham radio vernacular, a good power supply is a “stiff” supply.

Lab power supplies

A reliable, line-powered laboratory power supply is useful for checking circuit boards. No lab should be without one. A big advantage of commercial lab supplies is that the voltage is adjustable from zero to some high level like 20 volts. Meters show you the current and voltage at every moment, so you know what is happening. Variable voltage allows you to power up a new circuit *CAREFULLY*. You can start with a few tenths of a volt and see what happens. If the circuit is shorted, you can find out with one volt applied to the circuit board, rather than blasting it with 12 volts right away. This helps you to avoid burning up expensive transistors. Many lab supplies put out two or even three separate supply voltages at once. Another feature of some lab power supplies is that they automatically limit the available current to some maximum that you select.



Bench power supplies are quite generic and there are many modern ones that will serve you well. Remember, to power your QRP you need about 1.0 ampere at 12 volts DC. A typical modern, transistor QRP transmitter runs on a 12 volt power supply but its efficiency is only about 50%. Therefore,

$$10 \text{ watts} = 12 \text{ volts} \times 800 \text{ milliamperes}$$

Homebuilt power supplies for use with rechargeable batteries or line power are described below. If you aren't familiar with power supply design, a discussion of the basic principles follows.

Simple wall-powered supplies for 120 Volts AC

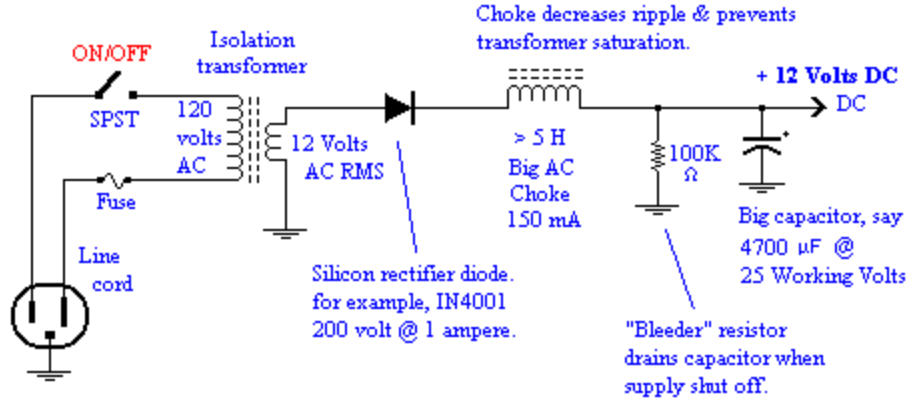

SIMPLE LINE-POWERED 12 VOLT POWER SUPPLY. (NOT SUFFICIENT FOR QRP)

The diagram above illustrates the simplest, safe, generic, line-powered power supply you can build. Unfortunately, this supply is too poorly regulated to power a transmitter. However, it illustrates the minimum safety features and it's easy to explain.

The following discussion assumes that the reader lives in North America where the standard household line voltage is 120 volts AC RMS @ 60 Hz. The safety issues explained here are applicable to other regions of the world. However, voltages, connector types, wire color codes, and ground configurations are often different. For example, in Europe the standard is 220 volts AC RMS @ 50 Hz.

Power supply safety

Metal enclosures. The supply should be enclosed in a box to insure that children (and you) won't get fingers across the 120 volts AC. Ideally the box should be made of metal so that, in case of a short circuit, a fire is highly unlikely.

Another safety design philosophy is called **double insulation**. In this scheme the electronics are housed in a plastic box and extra effort is made to insure that the internal wires are properly protected so that shorts and loose wires are highly unlikely. A double insulated plastic box does not necessarily need a ground wire in the line cord. However, in ham work, metal boxes shield circuitry from stray radio waves and are usually the best choice.

Line cord. The line cord should be the modern, three-wire type with the (green) ground wire securely connected to the metal box. In case a loose wire in the box causes the hot side of the AC line to touch the metal box, the ground wire will safely shunt the AC current to ground.

The line cord should pass into the metal box through a **rubber grommet** so that the metal edge can't cut through the insulation on the wire and cause a short circuit. Once inside the box, the cord should be held captive by a clamp, properly known as a **strain relief**. The strain relief insures that if the power supply is ever yanked by its cord, the live wires will not be ripped loose and short out.

4. Chapter 8, Harris

The wires in a line cord are usually color-coded. The “hot” wire usually has **black** insulation while the “neutral” or return wire is **white**. The third **green** safety wire is connected to power line ground. It should be connected directly to the metal chassis. The neutral wire is also supposed to be connected to the house ground buss out in the circuit breaker box. Looking at a North American household three-prong socket, the round pin is the “ground” and is connected to the green wire. The wider, flat pin is the hot side and the narrower flat pin is neutral. Unfortunately, sometimes wall sockets are wired wrong, so it’s better not to bet your life on the orientation of the flat pins.

Fuse. The first destination of one of the two power wires should be a **fuse**. As you probably know, fuses are little pieces of solder-like lead mounted in a glass case. When the current exceeds some calibrated level, like one ampere, the lead melts and the circuit opens. Fuses, of course, can only be blown once and can’t be reused. A fuse is represented on the diagram by the squiggle in the diagram labeled “1A,” meaning “one ampere.” The electrical standards allow a fuse to be considerably larger than necessary, like 5 amperes and still give adequate protection against shorts.

Switch. The power switch can switch just one side of the line. Or, it is even safer to switch both sides of the power line at once. The switch should be rated for at least 125 volts AC and 3 amperes.

The transformer

After the power switch, the line current usually goes to the primary winding of a transformer. The transformer has two functions: first, it isolates your power supply from the household supply and from ground. This makes electrocuting yourself much less likely. As explained earlier, the AC lines supply 120 volts AC referenced to ground. The transformer secondary delivers AC power that has no relation to ground at all.

For example, I don’t recommend actually trying this, but suppose you were to plug a well-designed transformer into a wall socket. And suppose that this transformer has high voltage secondary wires left dangling open circuit: Because of the isolation, you could touch either secondary wire without being shocked, even if your other hand were hanging onto a grounded water pipe. Of course if you touch both high voltage wires simultaneously, they will blast you.

A secondary winding is isolated from ground - like a battery floating in mid-air

Think of isolation as a battery hanging from a balloon. Electric circuits require a closed loop in order for current to flow. For the dangling battery, the current can only flow from one end of the battery to the other. There is no relationship to ground. If a person standing on the ground reaches up and touches the battery, no circuit loops are completed, so no current flows.

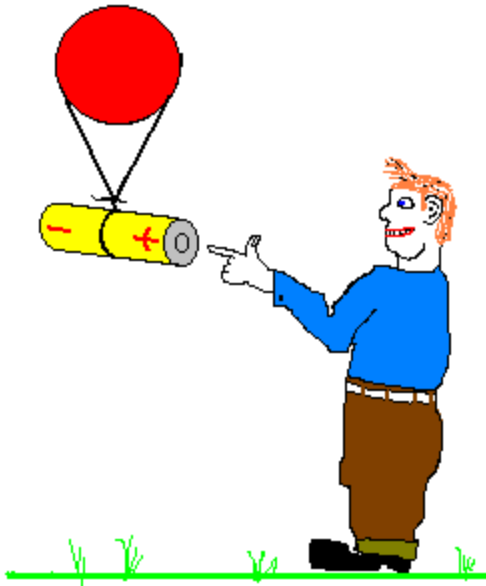

As explained in Chapter 2, transformers can change the ratio of current to voltage in proportion to the number of turns of wire around the core. To convert 120 volts AC to 12 volts AC, the turns ratio between primary and secondary coils would be 10:1. Or, if you needed to generate 1200 volts AC for an oscilloscope cathode ray tube (CRT), the turns ratio would be 1:10.

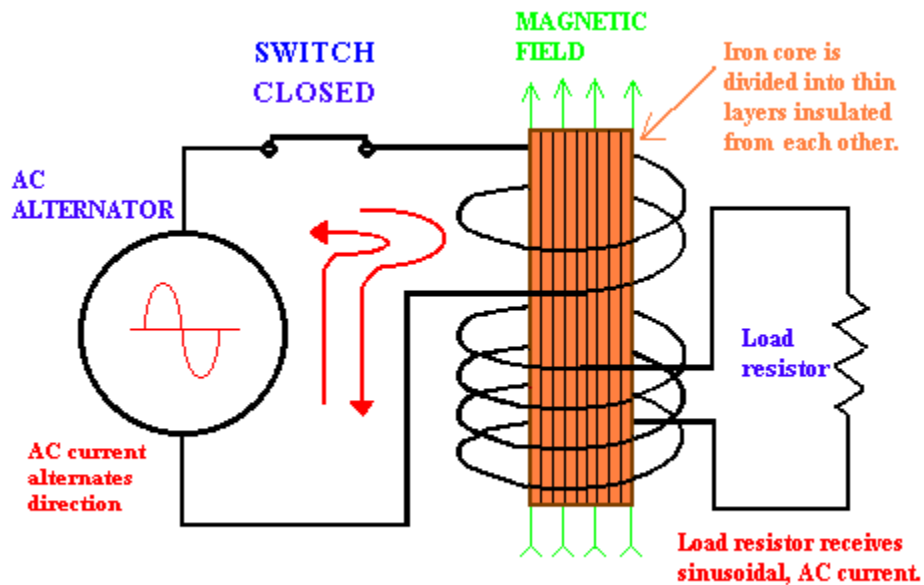

Transformers are not 100 % efficient. They are made from copper wire that has a significant resistance and iron that dissipates a small amount of energy as heat every time a magnetic field is generated or its polarity is reversed. In general, the larger the transformer, the larger the diameter wire used on the windings, the higher the efficiency will be.

Iron has a definite and abrupt limit on how much magnetic field it can support. Once all the iron has been magnetized, the iron will contribute no more magnetic field, no matter how much more current flows through the primary. Obviously, the larger the iron core, the more energy the iron can pass on to the secondary before the iron saturates. As a general rule, the larger the transformer, the more power it can pass through its windings.

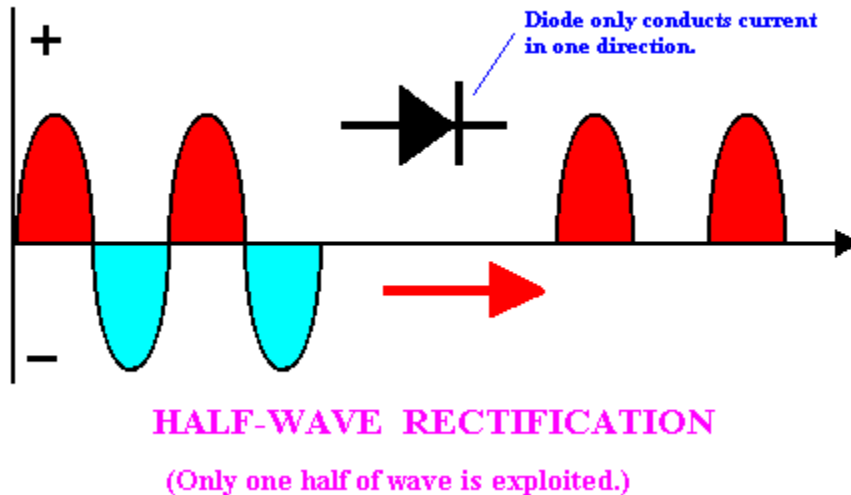

Rectification

Most electronic devices require DC voltage to work properly. AC is converted to DC by means of rectifier diodes. Rectifiers are high-power, high-current, high-voltage versions of the diodes used in crystal sets. Referring to the simple power supply shown earlier, the transformer is followed by a rectifier diode. *The diode only passes positive current flow in the direction of the arrow.* This means that current leaving the diode is in the form of “humps,” or half sine waves. Only half of the sine wave is passed through, so a single diode rectifier is called a *half-wave rectifier*. By definition these humps are “DC” since they have only one polarity. Unfortunately, for most electronics applications bumpy, intermittent sine-wave halves are grossly inadequate. For example, if you use them to power a CW transmitter, your signal will sound like an unpleasant buzz and it will take up 120 Hertz of bandwidth. In the 1920s this was often done deliberately to modulate Morse code and make it audible in a receiver without a BFO. If you tried to run a computer microprocessor on these humps without filtering, the processor would reset 60 times per second.

Peak Volts, RMS volts, and DC volts

Obviously sinewaves don’t stand still at any one voltage, so how are they measured? If the sine wave reaches peaks of plus 12 volts and minus 12 volts, then most of the time the output from the rectifier will be much less than 12 volts. Also, the positive voltage seems to cancel the negative voltage so that the arithmetic average of any sine wave voltage is zero. Obviously that measurement isn’t useful either.

Rules are needed to name sine wave voltage and current. As you might expect, *peak voltage* is the voltage difference between zero and the most positive extreme of the waveform.

Peak-to-peak or **PP** voltage means the voltage difference between the most negative peak and the highest positive peak.

As you may know, the voltage that comes out of North American wall sockets is officially **120 volts AC RMS**. During my lifetime American line voltage has also been nominally called "110 volts AC," "115 volts AC," "117 volts AC," and now it is called "120 volts AC." Confusing, no? Anyway, the two power wires coming into your house from the power pole out in the alley nominally have 240 volts AC across them. Of course it was formerly called two times 110 volts AC or 220 volts AC. Some people still call it 220 volts. Line voltage is designed so that each of the two wires from the power pole is at 120 volts AC with respect to ground.

As explained in chapter 2, inside your circuit breaker box these two wires are connected to two big metal "buss" bars. There is a third, grounded metal bar that runs down between the two active buss bars. The individual circuit breakers snap onto these bars like cars on a railroad track. Heavy power circuits for your electric stove and clothes drier clip clear across the tracks to engage both lines for a total of 240 volts. Small circuit breakers just clip from one side to the ground bar to give you 120 volts for ordinary low-power circuits.

The **RMS** or **Root Mean Square** of a sinewave voltage is the peak voltage divided by the square root of two. RMS voltage can be thought of as "the effective average voltage." It can be used to calculate AC RMS current, power, and AC resistance and impedance. For example, 120 volts RMS is a sinewave with a peak voltage of 1.414 times the RMS voltage. In other words,

$120 \text{ V RMS} \times \sqrt{2} = 120 \times 1.414 = 169.7 \text{ Volts Peak}$. Therefore, ordinary household line voltage could be expressed as **120 Volts RMS, 170 Volts Peak** or **340 Volts Peak-to-Peak**.

Filter capacitors - filtering out the ripple

The half sinewave bumps, which are properly known as "ripple," must be smoothed out into a continuous DC voltage. This is accomplished by means of a **low pass filter**. In this case low pass means that the filter only passes frequencies well below 60 Hz. DC is of course zero Hertz, which is the lowest frequency possible. The half-wave rectified supply illustrated earlier is equipped with an L-C "L" filter. L- filters are simply two-element filters that represent the two legs of the letter "L."

Capacitors conduct AC and prevent the flow of DC. Inductors conduct DC but resist the flow of AC current. In an effective DC filter, the component values will be huge, like 10 henries and 5,000 microfarads. This is because the frequency we want to filter out, 60 Hz, is extremely low and big components are needed to have an effect on such a slowly changing sinewave.

Bleeder resistor across the capacitor

The purpose of the bleeder resistor across the filter capacitor is to discharge it when the supply is not in use. Remember that high quality capacitors will hold their charge for many hours, sometimes days. Bleeders usually aren't important with a low voltage supply like 12 volts. But if this were a 500 volt supply, a person could get a nasty jolt or burn if they were to touch the capacitor. This could happen even though the supply is no longer turned on or plugged in.

If you were to build the half-wave supply shown earlier and put a 10 watt load on it, with

an excellent transformer and a really huge capacitor, perhaps the DC voltage will at least be continuous. However, there will still be a 60 Hz sinewave ripple or waves impressed on top of it. If you used it to power a transmitter, the tone of the Morse code would have a distinct rough sound as the DC level varies at 60 times per second. When hams gave you a signal report they would say that your signal tone was a number much less than 9. For example, they might send “UR RST 595.” (RST means Readability, Strength and Tone. Hams use a scale of 1 to 5 for readability, and 1 to 9 for both strength and tone.) Because of the harsh note of your tone, you might only rate a “5.” For this reason, transmitter power supplies always use dual rectifiers to produce *full-wave rectification*.

Full-wave rectifiers

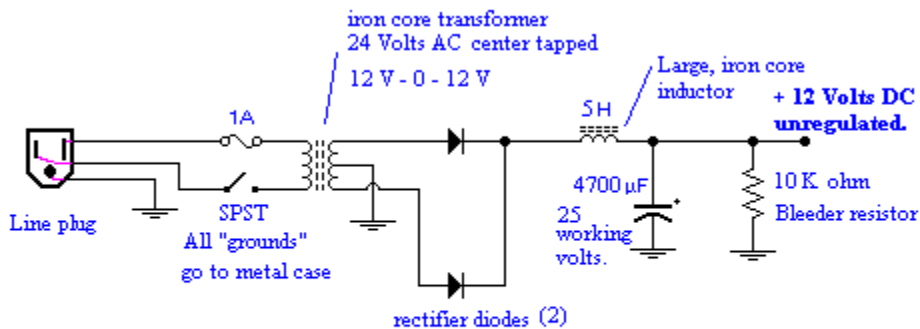

FULL - WAVE RECTIFICATION USING A TAPPED POWER TRANSFORMER

Full-wave rectifiers convert both halves of the sinewave into useful DC current. The DC voltage is now a succession of “humps” with no “off” intervals. With twice as many “humps” per second, the voltage is much easier to filter. Full-wave rectification is a big step toward producing a DC source that resembles the smooth continuous voltage available from a battery.

There are two ways to achieve full wave rectification. The circuit above uses two diodes. What you probably didn’t notice at first is that the secondary of the transformer has *TWO* 12 volt RMS AC windings. By having two separate windings, and wiring them in series, one of the windings can be positive at all times. This allows positive current to flow through one of the two diodes at all times and greatly decreases the ripple. Notice that, if we wanted, we could reverse the polarity of the diodes and produce the same waveform with the opposite polarity. That is, if we wanted a *NEGATIVE voltage source* referenced to ground, reversing the diodes would do that.

Bridge rectifiers

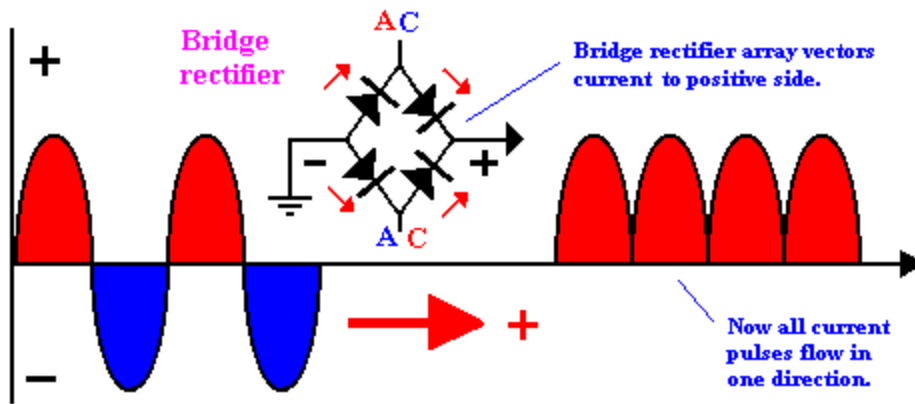

FULL WAVE RECTIFICATION
 (Both polarities of sinewave are exploited.)

The second way to achieve full wave rectification is to use a bridge rectifier made from four individual diodes. This configuration allows us to get full wave rectification from a single secondary winding. The four diodes are soldered in a diamond pattern as shown above. The AC voltage source is applied across the top and bottom of the diamond. The two diodes on the right are pointed so that the positive current will always flow to the positive side. The left side is wired to ground and the diodes point in such a way the negative current is always vectored toward ground. To say it another way, the positive current always flows “UP” from ground.

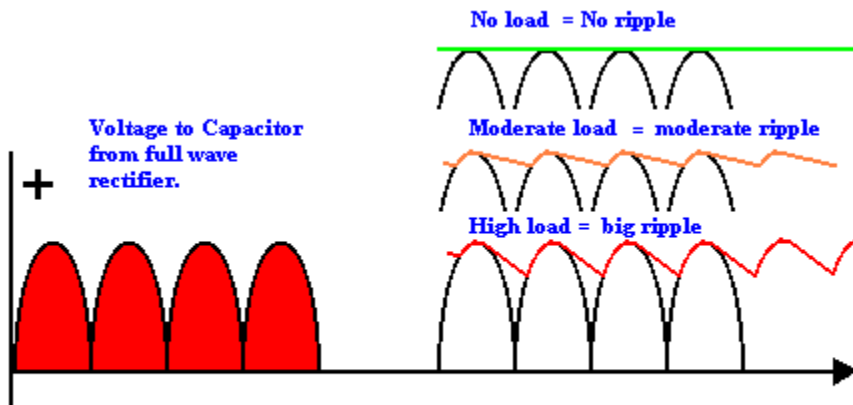

Effect of Load Current on Power Supply Ripple.

Ripple

Because the rectifier is supplying current in the form of “humps,” the voltage output across the capacitor will also vary up and down. If the capacitance is large the voltage doesn’t drop to zero during the “valleys,” but it can drop fairly low if the current drain from the supply is large. The more current that is sucked out of the capacitor, the lower the voltage “valleys.” This is illustrated in the drawing above. If the choke is large enough, it will work with the capacitor to smooth out the height of the voltage peaks and raise the level of the valleys dramatically.

With no load current, output voltage charges to the peak voltage

Notice that, if the power supply is not connected to an external load, the output voltage will rise up to the maximum voltage that comes through the rectifiers. For a 12 volt RMS transformer output winding, this is approximately the square root of two (1.414) multiplied times 12 volt RMS volts, or about 18 volts. Referring to the diagram, with no external load the only load on the capacitor is the tiny one milliamperere current passing through the bleeder resistor. This means that the variation in voltage between the humps will be extremely small. In summary, if there is no load on the power supply, to a voltmeter it looks like a “regulated” 18 volt power supply with essentially no ripple. If your 12 volt circuit might be damaged by 18 volts, you must not connect a supply like this to your circuit.

When you first turn it on, the voltage will be 18 volts for a moment before the load current flow is established and the choke and capacitor pull the peak voltage down. RMS (Root Mean Square) refers to the *AVERAGE* voltage of the rectified sine wave “humps.” If the output from the big capacitor were fed directly into your QRP without a regulator, the capacitor would charge toward the peak voltage of the “humps.” Depending on how much current your QRP was drawing, 18 volts might destroy some of the components in your QRP. As the load on the power supply is increased, the output voltage would drop down toward the rated RMS voltage, 12 volts. As the rated transformer load, say 3 amps, is exceeded, the DC voltage will probably drop below 12 volts.

Power transformer saturation

A second purpose of the choke (series inductor) is to prevent the peak current from the transformer from exceeding the current rating of the transformer. If the choke were not located between the rectifier and the capacitor, the current from the “humps” would only flow into capacitor when the voltage from the rectifiers is higher than the voltage already stored in the capacitor. It is like a tidal pool alongside the ocean. The pool can only fill with water when the tide rises higher than the level of the pool. The result of these pulses of charging current is that the power transformer must provide much more peak current than it may be rated for. If a transformer is rated for, say 10 amperes RMS, and these surges of current are drawn in bursts just a few microseconds long, then the peak current might be 100 amperes. Since the transformer doesn't have enough iron for that, the iron saturates and the transformer inductance momentarily collapses. Suddenly, the transformer will act like a few turns of copper wire shorting out the AC source. Saturation causes the windings and the transformer to heat rapidly and perform poorly.

Substituting big chokes with small, cheap resistors

In the real world, most low voltage power supplies like this solve the problem with a cheap resistor instead of a large, expensive iron core inductor. Resistors waste energy, but what the heck! You can use the resistor with an extra-large filter capacitor that costs less and weighs less than a choke with equivalent filter value. Or, as we'll see shortly, a linear voltage regulator can put a load on the capacitor all the time so that the current flow is not just in short bursts.

Regulators

To provide pure DC at a constant voltage over a wide range of load current, you need a regulated power supply. The regulator's first task is to “trim off” unwanted peak voltage and provide a DC voltage equal to (or similar to) the transformer rated RMS voltage. Regulators

solve the 18 volt over-voltage problem described above. Its second purpose is to maintain constant voltage even when the load resistance is changing continuously or during a line voltage brown out. A regulator circuit is usually added to a power supply like the one above. There are two basic designs for regulators, *linear regulators* and *switching regulators*.

Linear regulators are a sort of automatic variable resistor placed in series with the output of a simple supply like the ones we have been discussing. The regulator uses feedback from the load voltage to change the size of the “automatic resistor” and hold the load voltage constant. For example, in the above power supply the regulator input voltage might vary from say 15 to 18 volts, but the regulator would change its resistance to hold the output constant at 12 volts DC. *A linear regulator not only insures that the load voltage is always the same, it also “trims” off the ripple.*

Switching regulators are more complex circuits that usually involve inductors (or transformers) and switching transistors. They start with unregulated DC and turn it back into AC power. This AC power is then passed through a transformer to generate whatever voltage is needed above or below the original DC voltage. In an equivalent method, the unregulated DC is pulsed through an inductor to generate higher or lower voltages. Some switching regulators work directly off the household line. In other words, the 120 volts AC is rectified without a transformer and results in roughly 120 volts DC that is then converted into AC to drive a small, high frequency transformer or a step-down inductor. For amateur radio work, switchers usually make radio noise that you will hear in your receiver. Yes, commercial radio equipment often use switchers in their designs, but in my experience, getting rid of the switching noise is extremely difficult.

In contrast to switching regulators, some switchers just boost the voltage, but don't regulate the output voltage. These are often called *charge pumps*. The noise from these unregulated charge pumps can be insignificant because they only switch at one frequency and they don't “dither” back and forth trying to hold the output voltage constant. In summary, *regulated switchers are noisy* and I have pretty well given up trying to use them inside ham equipment.

Zener diode regulators

The simplest regulator is made from a *Zener diode*. It is a “*linear regulator*” because there are no abrupt pulsed signals involved and it works entirely with DC. It dissipates the unwanted voltage as heat. A Zener diode is a modified silicon diode subtly different from the rectifiers used in the power supplies above. Zener diodes are made from silicon that has been doped (contaminated) with extra ions. The extra ions cause the diode to break down at a specific lower reverse voltage when a high reverse voltage is applied. Zener diodes are inferior rectifiers, but when used as regulators, they are quite useful.

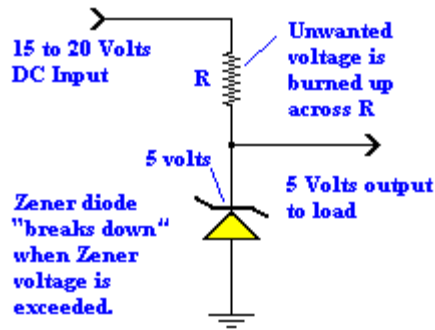

Why ordinary rectifiers don't behave like Zeners

Diodes rectify because the reverse voltage is insufficient to force electrons through the P side of the P-N junction that has no free electrons. However, when enough voltage or “electrical force” is applied, the P-N barrier breaks down in an *avalanche breakdown*. When this breakdown happens at high voltage and high current, the sudden heat generated may ruin the diode (or bipolar transistor). You may remember the homemade crystal diode discussed in chapter 4. When this crude diode was reversed biased, it broke down abruptly at about one volt. At any voltage above 1 volt, it acted like a short circuit and regulated the load voltage to one volt. At low voltage levels, such a breakdown doesn't necessarily destroy the diode if the diode doesn't overheat. This *Zener voltage* level can also be used as voltage reference.

Doping silicon diodes makes Zeners

When big, tough, modern 400 volt silicon diodes are “doped” with extra ions mixed into the semiconductor, the avalanche can happen at lower voltages anywhere below 400 down to as little as 3 volts. Because the load voltage is low, and the load resistance presumably limits the current to a safe level, the heating in the silicon is mild enough that the diode survives the breakdown. In practice, Zener diodes are available from about 3 to 50 volts. 100 volt Zeners would have to be capable of dissipating a great deal of heat or they would be easily destroyed.

In the circuit above the Zener diode breaks down at 5 volts. If one of these diodes is placed across a load, the Zener diode will clamp the voltage to 5 volts so the voltage across the load never rises above 5 volts. Of course the input voltage must always be higher than 5 volts and the unwanted voltage will be dissipated across the resistor in series with the power supply. Ohm's law tells us that half of the resistor current must pass through the Zener on its way to ground. So the Zener diode itself is dissipating as much energy as the intended load. As you can see, Zener diode regulators have poor energy inefficiency.

Real versus ideal Zeners

If a Zener diode behaved “perfectly,” the voltage across it would be the Zener voltage, no matter how many amperes flowed through the diode. This is illustrated by the green curve in the graph below. Unfortunately, the Zener voltage rises with large currents as shown below on the red curve. Notice that when the Zener diode is wired backwards, it acts like a normal, forward-biased silicon diode. Conduction starts at about 0.6 volts. Real Zeners look like ordinary forward biased silicon diodes. What is called “forward” conduction for a normal diode is called

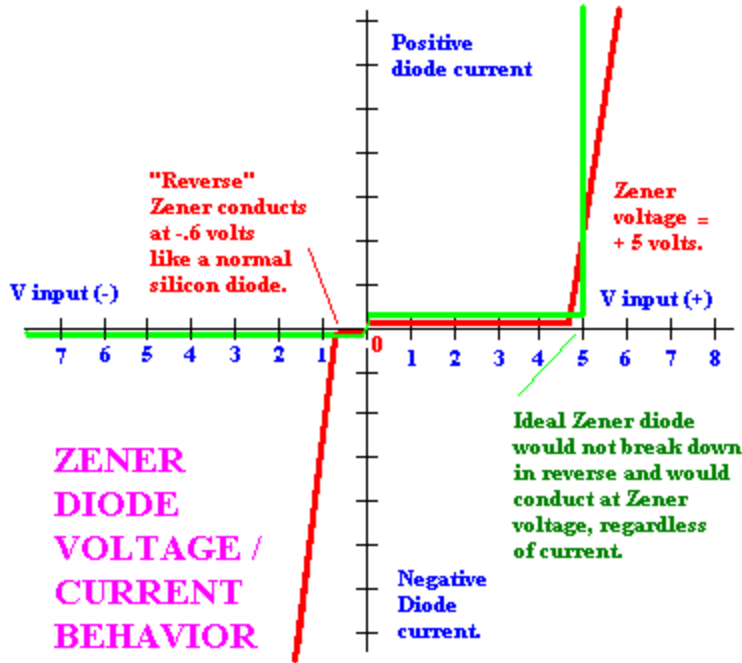

reverse conduction for a Zener. Zener diodes are impractical for heavy current regulation. They not only dissipate energy in the series resistor R, they also burn up energy in the diode. Moreover, as the diode current rises, the Zener voltage can be significantly different from its nominal value. In practice Zener regulation is used for light loads over a narrow range of input voltage. As you will see later, Zeners can be used as **VOLTAGE REFERENCES** to run a transistor regulator. In this way, the regulation can be fairly good and energy isn't wasted.

This will be illustrated in an application later in this chapter.

A homebuilt, line-powered power supply for a QRP

Now let's be practical: The 12 volt supply below worked well for me and can be assembled entirely from parts at your local Radio Shack.

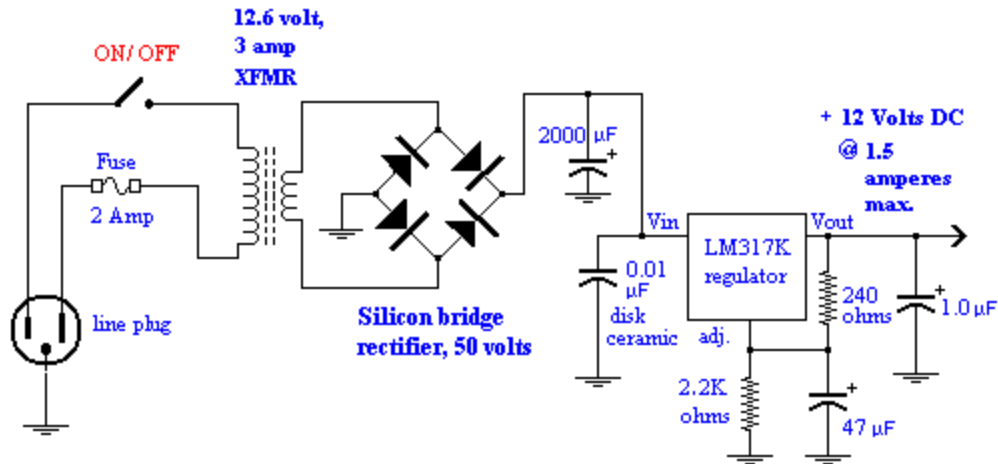

This 18 watt regulated line-powered supply should be built in a metal chassis. The round ground pin from the line cord should be connected to the chassis. In that way, if the "hot" black wire should break and touch the chassis, the metal would not become dangerous to touch. A 2 to 5 ampere fuse in series with the line input protects the supply. The ON/OFF switch should be rated for 250 volts DC and at least 1 ampere. The line cord should pass through a rubber grommet on the way into the chassis. Once inside, the line cord should be clamped to the chassis

so that, if someone picks up the power supply by the cord, the force will be on the clamp and not on the solder joint where the line cord is fastened to the fuse and switch.



The transformer is rated at 12.6 volts RMS at 3 amperes. I used Radio Shack part # 273-1511. The rectifier is a generic silicon bridge rectifier rated for at least 50 volts @ 3 amperes. Alternatively you could use 4 individual rectifiers arranged as shown above. The filter capacitor following the rectifier just needs to be large and greater than about 25 working volts. The other three capacitors serve to stabilize the output and prevent oscillations and ripple. Adding a 12 volt dial light so you will know when it is on is a nice touch.

The LM317K programmable voltage regulator

The LM317K regulator chip is packaged in a TO-3 metal case and can deliver 1.5 amperes. To dissipate the heat, the TO-3 case should be bolted to the metal chassis and insulated by means of a mica washer and silicon grease. Mounting kits for this purpose are also available at Radio Shack. This regulator chip works by regulating the voltage between the V_{out} terminal and the "adjustment" lead on the regulator. The regulator regulates this voltage difference to 1.2 volts. This low voltage allows the designer to regulate voltages equal to or higher than 1.2 volts. In this 12 volt application, the regulator passes current through a 240 ohm resistor and regulates the voltage across the 240 ohm resistor to 1.2 volts. This results in a "current source" that drives a regulated current through the 2.2K resistor to ground. This increases the total regulated output voltage from 1.2 up to 12 volts. In other words, 240 ohms is about 10% of the sum of 240 ohms plus 2200 ohms. Because you can "program" the total regulated voltage, this same regulator can be used to regulate voltages from 1.2 volts up to about 20 volts.

Another reason you need good voltage regulation is that the tuned stages in your QRP don't take kindly to changing the supply voltage. If you tune up the antenna using 12 volts, and the voltage later goes up or down, the tuning of some stages may change slightly and your signal might crash in the middle of a QSO (conversation).

The LM317K "clips off" any voltage above 12 volts so your QRP will never see a higher voltage. Notice that the LM317K is a ***linear regulator***. This means that it turns any input voltage that is above the regulation voltage into heat. This seems wasteful, but linear regulation makes no radio noise and produces a flat output voltage with practically no ripple. Notice that the choke (or a resistor) is not necessary here because the regulator is drawing current from the capacitor nearly all the time. This means that the current is flowing from the transformer nearly

all of the time and will not be saturated by high current pulses.

This power supply violates my goal to never use integrated circuits. If there are purists who share my aversion to integrated circuits, the “low dropout” regulator shown below can be substituted for the LM317K regulator. A larger power supply than this would be more versatile and could power a bigger transmitter. Obviously, the higher the power level, the more cumbersome the regulation becomes. Running a 100 watt transmitter requires a 300 watt regulated power supply. I sidestepped this project by running my entire ham station on a solar-charged 12 volt battery which is described later in this chapter.

A low dropout voltage regulator for use with a battery

As you will read shortly, a lead-acid golf-cart battery makes a fine, high-current 12 volt power supply. Unfortunately, running your transmitter on batteries means that, when the battery is ready to be recharged, its voltage will drop down to 11 or even 10.5 volts. This means that (ideally) your QRP must be tuned up to run on 10.5 or 11 volts and then regulated to that level. Remember that *a linear regulator can only deliver LESS than its input voltage*. So if you’re running on a 12 volt battery, you need a regulator that wastes as little voltage as possible. This waste voltage is called *dropout*. The regulator shown below receives nominal 12 volts from a battery. The active regulation element is a big P-channel MOSFET transistor. This transistor can be arbitrarily large. The bigger it is, the less voltage it will waste and the lower the “drop out.”

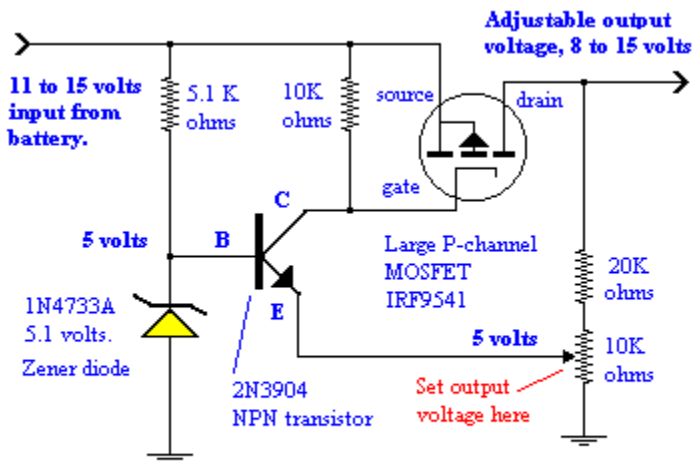

The P-channel MOSFET transistor turns on (conducts current) when its gate voltage is pulled downward toward ground. So when the battery voltage drops, the gate voltage must be pulled down (toward zero volts) to turn the MOSFET more on. When the battery input voltage rises, the gate voltage must be raised to turn the transistor more off and restore the output to the set voltage.

Low Dropout 12 Volt Power Supply

The gate voltage control is done with an NPN bipolar transistor. The transistor compares the reference voltage across a 5 volt Zener with a fraction of the output voltage across the sense resistor pot on the lower right. The slider on the sense resistor contacts the resistance at a level that produces about 0.6 volts less than 5 volts. As the output voltage rises, the voltage on the sense resistor rises. This in turn increases the transistor emitter voltage. The difference in voltage between the base and emitter drops, causing the drive to the NPN transistor to drop. As the NPN transistor turns more off, the gate voltage on the MOSFET rises toward the battery voltage and turns off the MOSFET and lowers the regulated output voltage.

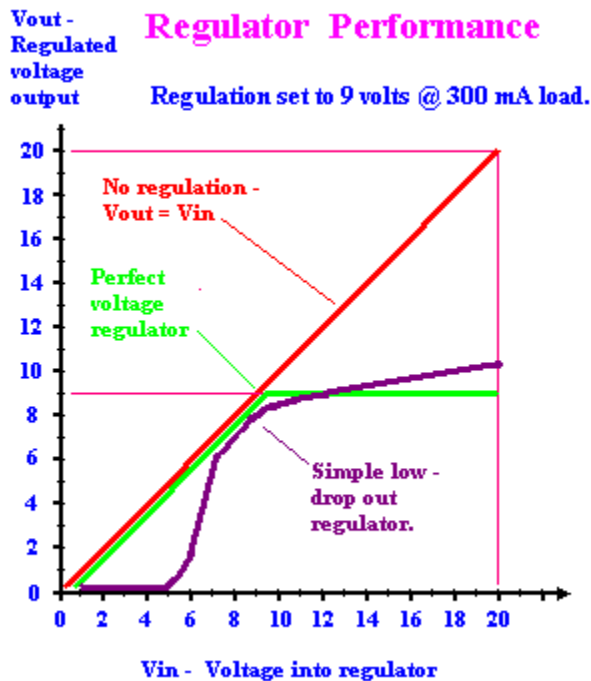

The purple plot on the left shows the performance of this simple power supply when it has been set to 9 volts with a 300 milliamperere load. The red line shows the voltage the load would receive if there were no regulation. That is, $V_{in} = V_{out}$. The green line illustrates the performance of an ideal or perfect linear regulator. If the transistors had infinite gain and the Zener diode always produced precisely the same reference output voltage, then the green curve is what you would get. As soon as the regulator is given 9 volts input, it would deliver exactly nine volts, no matter what the load was.

As you can see, the simple regulator isn't radically different from ideal, but it is much less then perfect.

A precision, temperature-compensated, low-dropout regulator

More nearly perfect regulation can be achieved by replacing the NPN transistor with an operational amplifier. Operational amplifiers, op-amps, are integrated circuits composed of many or even dozens of transistors. Op-amps perform as though they were nearly perfect transistors. Similarly the LM336 voltage reference is an integrated circuit made from bunches of transistors that perform as though they were a nearly "perfect" Zener diode. As the voltage across the regulator is varied, the voltage across the Zener remains constant within a couple thousandths of a volt.

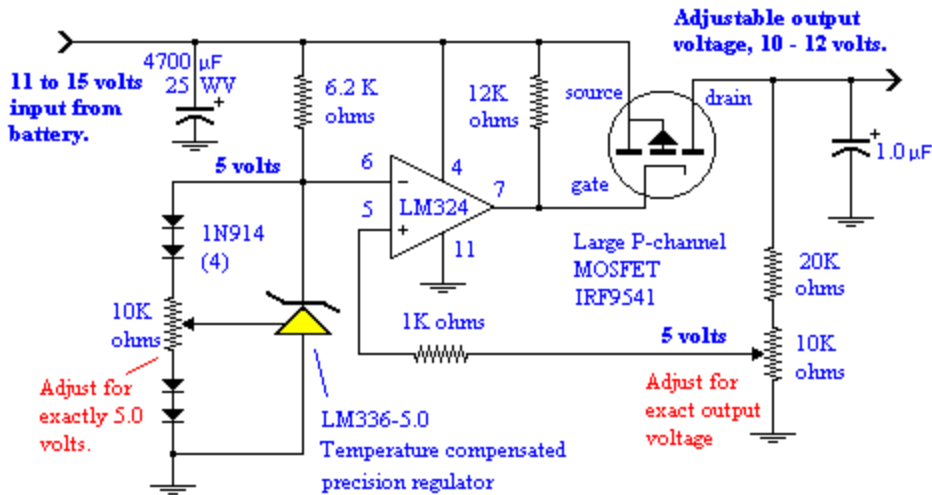

Low Dropout 12 Volt Power Supply with Precision Regulator

The op-amp is the triangle in the center. This op-amp has 14 pins and the numbers shown are the pin numbers. This particular chip contains four op-amps. Only one is used in this circuit. Pins 6 and 5 are the inputs. The input pins function in such a way that the op-amp changes the output voltage (pin 7) to “try” to keep the two input pins at the same voltage. That is, so long as the voltage on pin 6 is identical to the voltage on pin 5, the output remains constant. When the **positive** pin 5 has a higher voltage than the **negative** pin 6, the output pin will shoot positive as high as it can go. When the negative pin 6 is higher than pin 5, the output pin will zoom negative as low as it can go.

Unlike simple transistors, the op-amp has nearly infinite voltage and current gain. Gains like 100,000 or a million are common. Also, the inputs draw essentially no current. They have nearly infinitely high input resistance. This means that op-amps are ideal to “monitor” some condition, such as the output voltage from the power supply, and then change the OP-AMP output pin voltage in order to restore the supply to equilibrium. Looking at the diagram, pin 6, the negative input, always rests at 5.00 volts, so long as the battery voltage input is at least 5 volts. The output voltage pot at the lower right is adjusted to produce the desired output voltage. The big MOSFET transistor will remain turned on to the exact degree to deliver the voltage you set. This set point is the place where 5 volts appears on the pot. As soon as the op-amp “sees” that pins 5 and 6 have the same voltage, the output voltage on pin 7 holds still and stops changing.

A precision Zener diode

The LM336 precision Zener diode is not only extremely accurate, it will maintain its accuracy over a wide temperature range. Speaking of temperature change, don’t forget to bolt your MOSFET to a big heat sink. At high input voltages and big load currents, you may expect the MOSFET to get boiling hot without a heat sink. Keeping it cool keeps its internal resistance low and improves the regulation. The metal flange on the transistor should be insulated from the

heat sink and metal chassis with a mica insulator and silicon grease.

As we shall see in chapter 10, building a variable frequency oscillator that reaches modern standards of frequency drift requires the use of a super-regulated power supply. This in turn will require you to use regulators made from integrated circuits. Sigh. Of course you could prove me wrong by building one with discrete parts.

BATTERIES AS A POWER SUPPLY

The beauty of batteries

As I mentioned earlier, I run my whole station on solar power stored in a 12 volt battery. You're probably thinking, "Yeah. And I'll bet he voted for Ralph Nader." Now I know this sounds like pinko, tree-hugging, liberal silliness, but my solar powered station came about quite logically and has many advantages for a homebuilt station. There are lots of hams that do this - and no wonder! A lead acid storage battery is a wonderful power supply. It puts out huge currents whenever you need them and the voltage regulation is excellent. The best advantages are that batteries make no switching power supply RF noise and there's no waste heat from a big linear regulator.

My return to ham radio began in 1997 when I hauled my 1967 homebuilt mobile ham rig down from the attic and blew off the dust. Since my old mobile rig runs on 12 volts, I couldn't even try out the receiver without a heavy-duty 12 volt power supply. I considered building or buying a supply but after 10 seconds I decided that was ridiculous. I happened to have some 6 volt golf cart batteries in the garage. I hauled two of them down to the basement and put on an automotive 12 volt trickle charger. After a day, the batteries recovered and I could fire up the rig. AM phone was extinct, but there was nothing to stop me from getting on CW, which I did with good success. Well, that's not quite true. My adventures included a drifting VFO and a blown 200 watt charge-pump switcher, but those problems had nothing to do with the power source.

My old vacuum tube rig was a power hog. The receiver drew 3.5 amperes at 12 volts. That's 42 watts just to listen! The transmitter was much worse, of course, but it isn't dramatically worse than a transistorized rig. After all, a transmitter can't radiate big power if it doesn't draw big power. Moreover, a modern, linear, class A transistor rig can be even more inefficient than an old Class C vacuum tube transmitter. Either way, my transmitters draw 6 to 18 amperes.

Compared to a golf cart or an automobile starter motor, a ham rig is a low power device. 20 amperes should be plenty of current. A deep discharge storage battery is best, but there's no reason you can't use an old car battery. We all routinely discard car batteries when they can no longer supply 400 amperes on a January morning. But even an old car battery will usually supply 20 amperes for five minutes without appreciable voltage drop. All you need to do is keep a small, one-ampere charger on it continuously. For anyone on a budget, a free used battery is a darn cheap high current regulated supply.

Requirements of a line-powered 20 ampere, 12 volt supply

I don't plan to build an equivalent line-powered power supply. But if I did, I wouldn't

build a switching power supply. I've had zero luck running ham equipment on switchers. If the switcher is more than just an asynchronous charge pump and actually regulates the output voltage, then it will make RF noise which you'll hear in your receiver.



A 1967 homebrew all-band transmitter with a switching power supply running on 12 volts DC

The 150 watt switching supply is at the left rear. Originally the supply was a simple charge pump that used germanium power transistors. It consisted of a free-running multivibrator circuit that drove a step-up transformer with no feedback. The supply worked well and didn't produce audible hash in my receiver. Then one day a germanium transistor blew and I was unable to find a suitable replacement. I rebuilt the supply using a modern pulse width modulator regulation system and MOSFET power transistors. A neat feature of the new switcher was that the output voltage was adjustable. Just by turning a knob I could vary the transmitter output power from 20 to 80 watts.

Unfortunately, the switcher and the RF amplifier stages “talked to each other.” That is, when the load increased, the supply increased the pulse width modulation to compensate, but not without a slight delay. This subtle ripple or “jitter” was hard to see on a scope, but no matter how much I filtered it, the jitter appeared as a slightly rough note on the CW signal. In practical terms, I kept getting 598 RST reports.

There was an elaborate 12 volt switcher in QEX magazine a few years ago that solved the jitter noise problem. I was delighted to see that I wasn't the only one who noticed “jitter noise.” The problem is real, but after seeing the complicated Rube Goldberg solutions, my desire to build one vanished.

If I had to build such a supply again, one method would be to build a charge pump or other unregulated switched system that boosted (or lowered) the input voltage to just above the desired voltage. Then I could use a linear voltage regulator to accomplish the regulation function with a minimum of waste heat generated. This is the low noise approach I used to power my super-regulated miniature VFO power supplies described in chapter 10.

One feature of a high power charge pump I would test would be to use a manually adjusted pulse width for the AC generation. This way the output voltage could be manually set so that the linear regulator would waste as little energy as possible. This regulation margin would depend on how consistent my line voltage was and how stiff the charge pump conversion system was. For example, starting with 120 volts AC, the charge pump might lower the voltage to say, 20 volts DC. Then the linear could reduce the 20 volts DC down to 12 volts.

Going solar

Because my trickle charger was feeble, I was charging non-stop. Even then, I was having trouble keeping the battery charged for a couple hours of daily operating. However, I already owned a 12 watt, 12 volt solar panel which I installed on the roof.

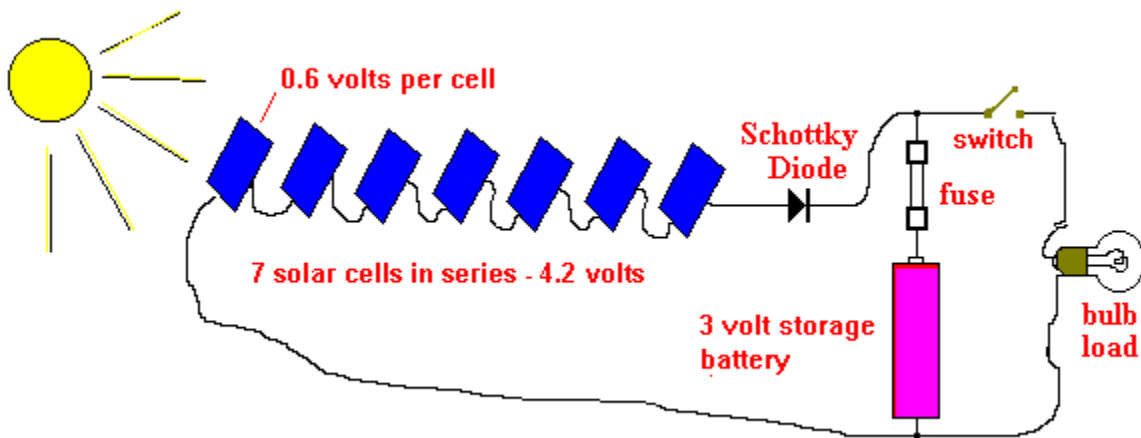

A simple solar charger circuit

Solar cells are a kind of silicon diode. They are arranged in series so that the forward voltage drop of each diode adds up to some voltage greater than the voltage of the storage battery. For example, at 0.6 volts per solar cell, we need at least 20 cells in series to raise the panel voltage higher than the 12 volt battery. Typically, an open circuited panel puts out 20 volts in bright sunshine. This extra capability insures that it will continue to charge a 12 volt battery all day and implies that there are roughly thirty 0.6 volt cells in series. Solar cells are interesting to play with. I was surprised to discover that if you put your hand over just one of the series cells, it turns off the whole string, something like Christmas tree lights wired in series. This means that just one wet leaf stuck on your panel can turn off the whole array.

The panel output current is proportional to the sine of the angle the sunlight makes with the panel. If your object is to produce the maximum kilowatt-hours averaged over the entire year, then the angle should equal the latitude. I mounted my panel at 45° , which at 40° latitude, gives me better performance during the winter. Optimizing for winter is smart because the days are short and the panel is often covered with snow. Actually 50° may be better here in Boulder. Snow slides off a steep incline and higher angles are more resistant to hail damage. On the other hand, mounting them on a steep frame may make them subject to wind damage. There is no way to win. Many people just mount the panels flat on whatever roof they happen to have. If you wish to sacrifice some percentage of the output for beauty or mounting convenience, that's your decision.

The “lunar discharger”

It's bad form to connect a solar panel directly to a storage battery. The solar cells are forward biased diodes with respect to the battery. Therefore, whenever the sunlight quits, the panel voltage may drop below the battery voltage and a small battery current will reverse and flow through the solar panel. In other words, at night, the solar charger becomes a “lunar discharger.” (Never mind.) If there are enough extra solar cells, then the night-time voltage drop may still exceed the battery voltage. Anyway, the discharge problem is typically prevented by a silicon diode in series with the panel to insure that current is never allowed to flow from the battery back into the panel. Since this check valve diode has a forward voltage drop that wastes energy, you may as well use a big Schottky diode that will only penalize you with 0.2 volts instead of 0.6 volts loss.

Another small issue is lightning protection. My panel is on the roof where, in theory, it might attract a lightning bolt. I'm not really worried, but I have a connector on the lead from the panel so I can disconnect it from my shack when I go away on trips or whenever a storm is particularly frightening.



Solar panel on the roof

I built my panel frame out of varnished wood. The wooden boards screwed down to the roof retained water against the shingles and rapidly rotted. I replaced the boards with 2 inch aluminum angle stock which should be a permanent fix.

Conservation helps

My solar panel charges about as much as the line-powered trickle charger, about 1 ampere. Consequently I still had to use line power to charge occasionally whenever I stayed on the air too long. A breakthrough came when I built my new transistorized receiver. The new receiver draws 120 mA. That sure beats 3,500 mA. Since then, I haven't needed my line-

powered charger.

12 Volt power distribution

A storage battery can deliver hundreds of amperes, so it's wise to isolate the battery from your rig and solar panel with an appropriate fuse. A 30 ampere fuse should be about right. I have a master switch to isolate the battery from the ham rig when I'm not using it. A little LED pilot light tells me when it's connected and a voltmeter warns me if the battery is not fit for use. I also have charging and discharging ammeters (ampere meters) so I know the status of my supply at all times. I find the discharge meter helpful for monitoring my transmitters. You can even tune the antenna while watching the battery current. For fun I also have a small 12 volt lamp for emergency lighting.

Maintaining clean battery contacts is critical to keeping the supply voltage constant under load. Every few months, I clean the contacts and top off the batteries with distilled water. I can tell that the battery contacts need cleaning whenever the pilot light on my transmitter begins to flicker noticeably while I'm transmitting. A gel-cell battery shouldn't have these corrosion and fluid loss problems.

In summary, I get a kick out of operating like a fully solar-powered Field Day station. Because the whole station runs on 12 volts, in theory I'm always ready for Field Day and there's nothing to stop me from going mobile. One of my back-to-nature dreams is that, during a power failure, I can go right on operating and thumb my nose at the evil corporate power monopoly. Twice during power failures I have galloped downstairs in the dark to make my first 100% truly independent radio contact. But before I could even tune the transmitter, the *#@%!\$ lights came back on. Oh, curse those efficient fellows at Xcel Energy Company!

LED THERE BE LIGHT

Emergency Station Lighting

As I explained above, I run my whole station on solar energy stored in a 12 volt battery. An advantage of battery power is that I operate free from the power grid. This saves very little money, but it's quite romantic. Of course at night, even on batteries I need to keep a log and throw the correct switches. Using candles or a flashlight clenched in my teeth didn't seem very sophisticated.

My first idea was to dangle a 12 volt automotive light bulb over my shack. My buddy Bob, NØRN, uses such a light in his tent on Field Day. This solution is completely practical, but it seemed old-tech and boring. It also draws about 10 watts of power. If I am going to all the trouble to build a custom 12 volt light, I figured it should at least be an interesting light. Modern lighting methods produce more light per watt than tungsten bulbs. Also, energy conservation is important when your station is powered by a battery charged with a small solar panel.



A homebrew LED and fluorescent station lamp

White LEDs – a modern marvel.

I happened to notice some “white LEDs” for sale down at Radio Shack. (Part # 276-320) I thought cynically that they were probably really dim and not really white. I bought one and hooked it to a variable power supply. I slowly turned up the voltage until I obtained the rated 20 mA DC current. Hey! Not bad! The beam of white light has a slightly bluish cast, but otherwise, it throws a spot of light out to a couple feet. It’s rated at 1100 mcd. That’s impressive brightness when you consider its beam angle is 100°. One LED makes a perfect key chain light and many LED flashlights are now on the market.

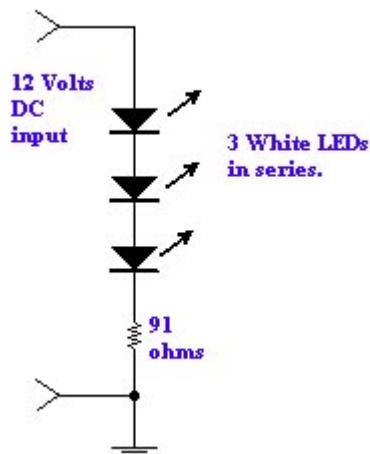

I’m told these white LEDs are made from sophisticated layers consisting of yellow and blue LEDs and a phosphorous that glows white. As LEDs go, it has a rather high voltage drop, 3.6 volts. I figured if I put three in series plus a single dropping resistor, it could run on 12 volts. The current is limited with just one 91 ohm resistor. The resulting triple light consumes just 0.25 watts and is adequate for keeping a log and operating the station. That’s amazing when you think about it. We routinely squander hundreds of watts to illuminate entire rooms when all we really need is ¼ watt to read our newspaper or book.

Flourescent lighting

Unfortunately, “adequate” isn’t the same as “comfortably bright.” So my next project was to build a 12 volt powered compact fluorescent. I fiddled for a couple hours trying to build a power oscillator capable of producing the required 800 Volts AC needed to ignite the miniature

fluorescent bulb. I had several transformer and switching transistor problems and solutions did not present themselves. I also fried my voltmeter because I forgot to change the range when I put it on the high voltage. There's nothing like dead test gear to make you think differently.

I remembered that I had still a 6 volt fluorescent lamp that I used to use for lighting my pup tent while camping. One day I rolled up the tent while the light was still hanging from the tent ceiling. Oops! The plastic housing was splintered and the remains of the light assembly were still in my junk box. I found the parts of the light and resoldered the broken wires. I connected it to a 6 volt power supply and it still worked fine. Next I built a shiny reflector/lampshade out of sheet aluminum and it produced loads of light. Unfortunately, I need a 12 volt light, not a 6 volt light. I didn't have a second light to put in series with the first, so I used a big dropping resistor to run the light on 12 volts. That worked OK, but it seemed pretty crude. Besides, I was already "cheating" because I hadn't built the fluorescent high voltage supply.

Nifty "buck-type" switching power supply

I replaced the dropping resistor with a switching power supply to reduce 12 volts DC down to 6 volts. I got the design from the National Semiconductor data book. Using the switcher the fluorescent light draws about 2.5 watts at 12 volts. The switcher is about 80% efficient. That is, it dissipates 10% of the total energy. In contrast a resistor would have dissipated 50% of my energy. I have used this little supply design for several home projects so far and found it thoroughly reliable. If you're a homebuilder, this simple, buck-switcher belongs in your bag of tricks. If you're bored with building a 12 volt light, maybe this little switcher will interest you.

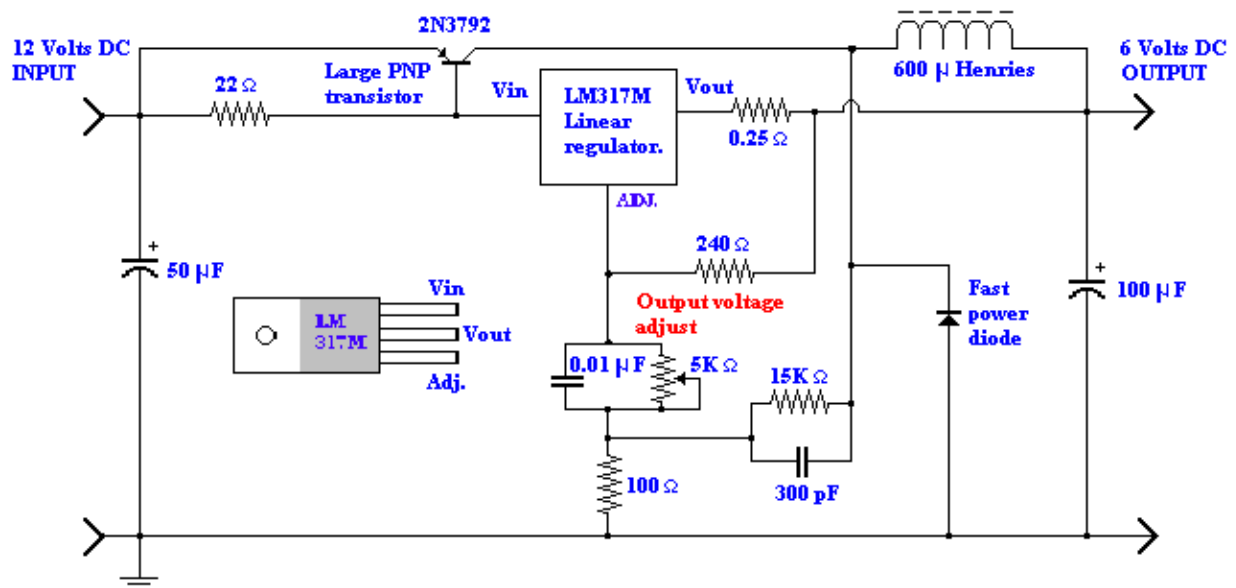

STEPDOWN SWITCHING POWER SUPPLY

(12 Volt DC to 6 Volt DC Converter)

Switching power supply made from a linear regulator

How can this work?

This switcher uses a LINEAR regulator to generate the pulsewidth modulation needed to implement a switching power supply. This is essentially the same linear regulator used in the suggested line-powered QRP power supply. But, when you put a scope probe on the inductor, sure enough! The linear regulator is switching full on and off in rectangular pulses. Apparently the 15K Ω resistor and 300 pF capacitor are coupling a feedback pulse from the inductor into the regulator to cause it to switch full on and full off. The pulse width varies with load and responds just like a real switcher. Aside from my amazement that linear regulators can work as switchers, I was also surprised that I hear very little switcher noise in my receiver. The RF noise it produces is apparently sufficiently isolated from the receiver that I rarely hear hash competing with the ham signals. On the rare occasions when I do hear it, I simply turn off the fluorescent.

Subjectively, the fluorescent produces roughly twice as much light as the LEDs. In other words, for ten times as much power the light seems to be twice as bright. On the other hand, it illuminates a much wider area than the LEDs, so I just run both of them simultaneously. The LEDs illuminate my log and scratch pad while the fluorescent lights up the station as a whole. I've used this light for hours at a time. It's bright enough that I'm content with it and I don't think about running across the room to turn on "the real lights." In summary, battery power and energy conservation are entertaining games. And, if we're really unlucky, someday our hobbies might even be useful in a community crisis.